

# Industrial Pumping Equipment

## Air-Operated Diaphragm Pumps

### 1/4" - 2" Air-Operated Pumps

#### Basic Design Features

Diaphragm pumps are driven by compressed air. The directional air distribution valve and pilot valve—the “air end”—are located in the center section of the pump. Liquid moves through two manifolds and outer chambers of the pump—the “wet end”. Generally, check valves are located at the top and bottom of each outer chamber or on a common manifold. The two outer chambers are connected by suction and discharge manifolds.

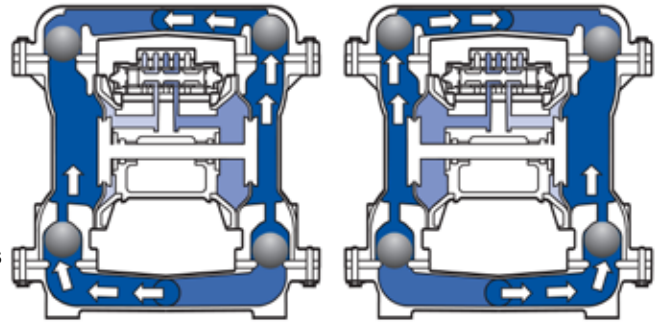

Right chamber—discharge  
Left chamber—suction

Left chamber—discharge  
Right chamber—suction

Lincoln’s double diaphragm self-priming design offers many advantages over other pumps.

- **Pump abrasive and sheer-sensitive materials.** Low interval velocities move abrasives easily with no damage. Gentle pumping action does not shear fragile materials.
- **Pumps viscous materials.** Even heavy or solids-laden materials can be pumped.
- **Environmentally friendly.** No motors, seals or packing to leak.
- **Self-priming.** Able to dry prime under most suction lift or flooded suction conditions.
- **Variable flow.** Regulate the inlet air supply to adjust flow.
- **Runs dry without damage.**
- **Deadheads against closed discharge.** Excessive back pressure stops operation without damage until discharge opens. Eliminates bypass systems or relief valves.
- **Explosion-proof.** Eliminates sparking concerns of other electrical or rotating pumps.



85630



85628

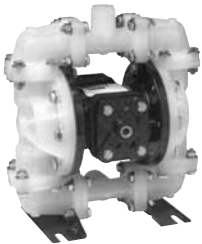

85622



85634

#### WARNING

The pump exhaust should be piped to an area for safe disposal of product being pumped in the event of a diaphragm failure.

### 1:1 Air-Operated Diaphragm Pump Line

| Model Number | Pump Description | Pump Body | Wetted or Soft Parts | Pump Inlet/Outlet NPT | Max. Free Delivery GPM | Air Inlet NPT(F) | Max. Rec. Inlet Air Pressure | Max. Susp. Solids | Application                    |
|--------------|------------------|-----------|----------------------|-----------------------|------------------------|------------------|------------------------------|-------------------|--------------------------------|
| 85630        | 1/4"             | Polyprop  | PTFE                 | 1/4" / 1/4"           | 4                      | 1/4"             | 100 psi                      | 1/32"             | New oil, AF, windshield washer |
| 85631        | 1/2"             | Aluminum  | Buna-N               | 1/2" / 1/2"           | 15                     | 1/4"             | 100 psi                      | 1/8"              | New/used oil, AF               |
| 85632        | 1/2"             | Aluminum  | Teflon®              | 1/2" / 1/2"           | 15                     | 1/4"             | 100 psi                      | 1/8"              | New oil, AF                    |
| 85633        | 1/2"             | Aluminum  | Hytrel               | 1/2" / 1/2"           | 15                     | 1/4"             | 100 psi                      | 1/8"              | New oil                        |
| 85622        | 1/2"             | Polyprop  | Santoprene           | 1/2" / 1/2" *         | 14                     | 1/4"             | 100 psi                      | 1/8"              | High abrasion materials        |
| 85623        | 1/2"             | Polyprop  | Teflon®              | 1/2" / 1/2" *         | 14                     | 1/4"             | 100 psi                      | 1/8"              | New oil, AF                    |
| 85626        | 1/2"             | Polyprop  | Buna-N               | 1/2" / 1/2" *         | 14                     | 1/4"             | 100 psi                      | 1/8"              | New oil, AF                    |
| 85629        | 1"               | Aluminum  | Hytrel               | 1" / 1"               | 45                     | 1/2"             | 125 psi                      | 1/4"              | New oil                        |
| 85628        | 1"               | Aluminum  | Teflon®              | 1" / 1"               | 45                     | 1/2"             | 125 psi                      | 1/4"              | New oil, AF                    |
| 85627        | 1"               | Aluminum  | Buna-N               | 1" / 1"               | 45                     | 1/2"             | 125 psi                      | 1/4"              | New/used oil, AF               |
| 85621        | 1 1/2"           | Aluminum  | Buna-N               | 1 1/2" / 1 1/2"       | 106                    | 3/4"             | 125 psi                      | 1/4"              | New/used oil, AF               |
| 85624        | 2"               | Aluminum  | Buna-N               | 2" / 2"               | 150                    | 3/4"             | 125 psi                      | 1/4"              | New/used oil, AF               |

#### Dual Inlet

|       |      |          |        |             |    |      |         |      |          |
|-------|------|----------|--------|-------------|----|------|---------|------|----------|
| 85636 | 1/2" | Aluminum | Buna-N | 1/2" / 1/2" | 15 | 1/4" | 125 psi | 1/8" | AF/Water |
| 85637 | 1/2" | Polyprop | Buna-N | 1/2" / 1/2" | 14 | 1/4" | 100 psi | 1/8" | AF/Water |
| 85639 | 1"   | Polyprop | Buna-N | 1" ANSI**   | 45 | 1/2" | 100 psi | 1/4" | AF/Water |
| 85638 | 1"   | Aluminum | Buna-N | 1" / 1"     | 42 | 1/2" | 125 psi | 1/4" | AF/Water |

\* Can be converted to dual 1/2" outlet. \*\* 85639 requires 275631 Adapter and 275632 Seal Kit for Pipe Thread installations

### U.L. Listed

|       |       |          |         |         |    |      |          |      |   |
|-------|-------|----------|---------|---------|----|------|----------|------|---|
| 85634 | 1" UL | Aluminum | Buna-N  | 1" / 1" | 45 | 1/2" | 50 psi * | 1/4" | Used oil, diesel, kerosene              |
| 85635 | 1" UL | Aluminum | Teflon® | 1" / 1" | 45 | 1/2" | 50 psi * | 1/4" | Unleaded gas, diesel, kerosene used oil |

\* 50 psi flammable liquids, 125 psi others.



### Wall Mount Brackets

#### Model 85255 Wall Mount Bracket

Wall mount bracket for 1/4" to 1/2" air-operated diaphragm pumps.

#### Model 84817 Wall Mount Bracket

Wall mount bracket for 1/2" to 2" air-operated diaphragm pumps.



### Other Accessories

#### Model 240994 Drum Adapter Kit

For use with 1/2" polypropylene AOD pumps. Includes 2" NPT(f) bung bushing, 1" x 36" suction tube and adapter.

240994

#### Model 275631 1" ANSI Flange To 1" NPT Adapter

Adapts 1" ANSI flange of 85639 polypropylene dual inlet pump to 1" NPT(f).PVC for low pressure installations. Three required to convert all pump inlets/outlets.

#### Model 275632 ANSI Bolt Kit with Seal

Attaches adapter to 85639 pump. One bolt kit required for each adapter. Three required to convert all pump inlets/outlets.

### Transfer Pump Accessories

#### Suction Kits

#### Model 84945 Suction Kit

For transfer of product from drums, bulk tanks or reservoirs. Includes bung bushing suction tube, hose and coupling assembly. NOTE: 2" x 1" bell reducer required for use with Model 1914, not included.



#### Model 85256 Suction Kit

Same as 84945 except for use with 1/4" AOD pumps.

### Used-Fluid Overfill Warning Valves

Float rises with used fluid to activate "whistle" warning at prescribed level.

#### Model 84815 Single Wall

For single wall tanks & drums in used fluid systems and above ground tanks.

84815

#### Model 84824 Double Wall

Same as 84815 except for double walled tanks and above ground tanks.

### 4-Way Valve

#### Model 84816

Four port, two position valve used in waste fluid systems. Enables one pump to pump into and out of drum or tank.

84816

### Thermal Pressure Relief Valve

#### Model 282902

Protect lube system components from high-pressure spikes caused by temperature change in a closed fluid network.

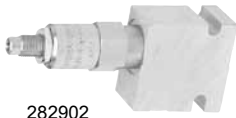

| Model  | Application               | Pre-Set Relief Pressure | Port Size |
|--------|---------------------------|-------------------------|-----------|
| 282902 | Diaphragm Pumps, 3:1, 5:1 | 150 psi (10 bar)        | 1/2" NPT  |
| 282876 |                           | 1000 psi (68 bar)       |           |
| 275197 |                           | 500 psi (34 bar)        |           |