

Modular Pumps

Lincoln's modular pumps are designed to efficiently supply either grease or oil in automatic systems using divider valve metering devices. Air, hydraulic and mechanically operated units are available. These units are then matched with an appropriate intermediate baseplate, and an appropriate reservoir to make up a pump assembly.

If required, the reservoir can be remotely mounted for ease of filling, utilizing a machine mounted baseplate and pump.

Baseplates contain all of the inlet and outlet connections for the pump and lube system. Intermediate baseplates mounted between the pump and reservoir allow for quick pump removal without disturbing any existing piping. Removal of the pump does not require draining of the reservoir due to an integral check-valve in the baseplate.

All modular reservoirs are compatible with all pumps, offering extreme flexibility in system design.

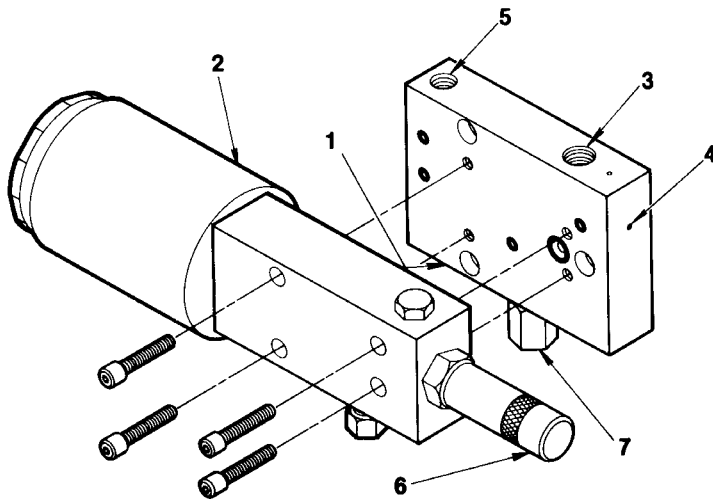

1. Base Plate
2. Pump Body
3. Lubricant Inlet
4. Bleed or Test Screw
5. Air inlet for both Single Acting and Double Acting Pumps
6. Adjustment Screw Assembly
7. Lubricant Outlet

PUMP & RESERVOIR

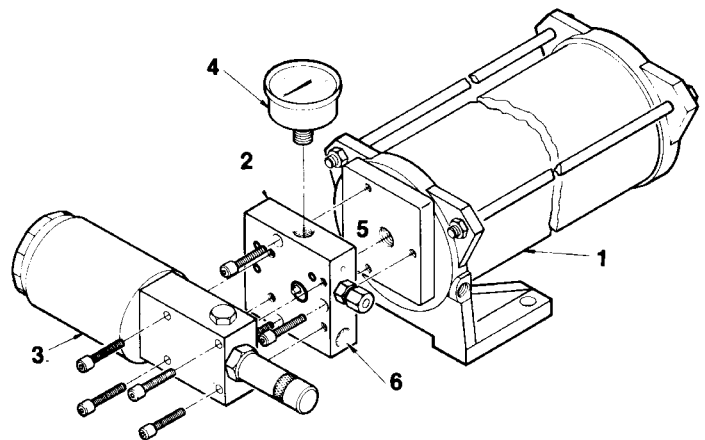

1. Cylindrical Oil Reservoir
2. Intermediate Base Plate
3. Modular Automation Pump
4. Pressure Gauge
5. Lubricant Inlet
6. Lubricant Outlet