

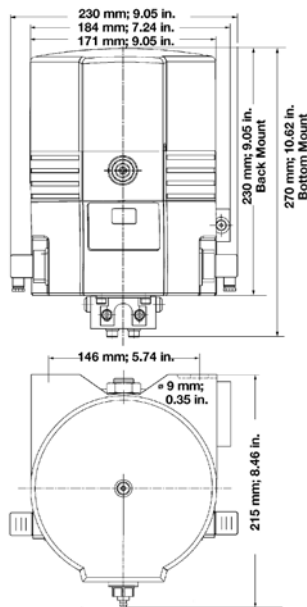

QLS 301/311 for Remote Control

The QLS 301/311 for Remote Control allows customers to be in control of the lubrication process. The 24 VDC models monitor system cycling with a proximity switch. An external timer or PLC controls the interval between lube cycles. The 120 VAC models have no cycle monitoring and are on/off controlled by the user's external timer or PLC. The minimum pause time requirements should be followed when setting up the external controller.

Operating Voltage:	24 VDC 120 VAC, 50/60 Hz
Operating Current:	24 VDC / 1.0 A 120 VAC / 1.0 A
Operating Temperature:	-10° to 158°F / -25° to 70°C
Number of Outlets:	6, 8, 12 or 18
Reservoir Capacity:	61 in ³ / 1.0 L
Protection:	NEMA 4
Minimum Pause Time:	4 min. DC models / 20 min. AC models
Maximum Operating Time:	25 min. DC models / 15 min. AC models
Timer Memory:	Indefinite
Maximum Operating Pressure:	Grease: 3000 psig / 205 bar Oil: 1160 psi / 80 bar
Output per Outlet & Cycle:	approx. 0.012 in ³ / approx. 0.2 cm ³
Lubricant:	up to NLGI 2 grease or oil with at least 40cSt.
Weight	12.5 lbs. / 5.7 kg



Model Specifications

Model No.	Valve Type	Valve Mount	Volt	Lubricant
P301 31411110	SSV6	Back	24 VDC	Grease
P301 61411110	SSV12	Back	24 VDC	Grease
P301 91411110	SSV18	Back	24 VDC	Grease
P311 31411110	SSV6	Back	24 VDC	Oil
P311 61411110	SSV12	Back	24 VDC	Oil
650-40768-3	SSV8	Bottom	120 VAC	Grease
650-40768-4	SSV12	Bottom	120 VAC	Grease
650-40768-5	SSV18	Bottom	120 VAC	Grease
650-40765-4	SSV8	Bottom	120 VAC	Oil
650-40765-5	SSV12	Bottom	120 VAC	Oil
650-40765-6	SSV18	Bottom	120 VAC	Oil