

Centro-Matic® Automated Lubrication Systems

Introduction



Lincoln Centro-Matic® systems and components are made to match your application. Systems can service one machine, different zones on one machine or even several separate machines. Regardless of the application, the principle of centralized lubrication remains the same: a central pump station automatically delivers lubricant through a single supply line to the injectors. Each injector serves only one lubrication point and may be accurately adjusted to deliver the precise amount of grease or oil required. Centro-Matic systems give you multiple advantages over other designs.

Simplicity

Systems are easy to understand, install and maintain. You realize savings right from the start because one lubricant supply line means lower installation costs.

Powerful Pumping Unit

Centro-Matic systems dispense either grease or oil in measured quantities, unaffected by normal temperature or viscosity changes. For large systems, Lincoln's single-line design and powerful pumps mean injectors can be located long distances from original refinery containers or bulk lubricant tanks.

External Adjustment

Lubricant injectors are externally adjustable without special tools so each bearing can receive the correct amount of lubricant. No under- or over-lubrication at individual points.

Visual Indicators

Each injector incorporates an indicator pin that gives visual confirmation the injector is operating correctly. When necessary, troubleshooting is the simple process of checking indicator pins.

Ease of Service

When injectors finally need service, the job is quick and easy. No need to remove supply line connections or disturb adjacent injectors. Replacement can usually be done between lubrication cycles, so there's almost no lubricant loss or downtime.

Parts and Service

You're never far from a Lincoln authorized distributor. Qualified distributors offer design engineering, startup help and training for your personnel in the use and maintenance of Centro-Matic systems. They'll back you up with parts and service for years after the sale.

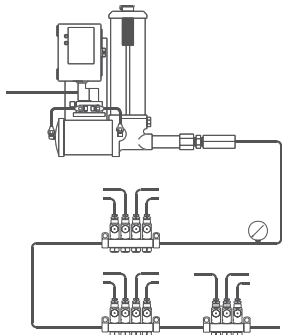

Air-Operated

Actuated automatically by compressed air at various pre-determined intervals. An air-operated pump delivers lubricant to the injectors. When all injectors have cycled, the pump shuts off automatically and vents lubricant pressure. Available with automatic, manual or mechanical controls.

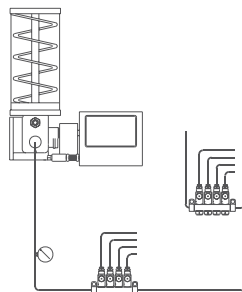

Electric

Used where compressed air is not available, or electrical operation is preferred. Totally enclosed motor supplies the power requirements of the pumping mechanism. Time control is adjustable to provide predetermined frequency of lubrication.

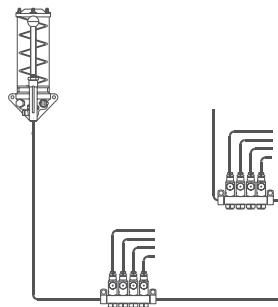

Manual

Designed for smaller, individual machines, manual systems provide a low-cost, efficient method of distributing lubricant to the injectors. Cycling a complete bank of injectors takes only a few seconds. In manually operated systems, the lubricant pump is hand-operated and the machine operator performs the lubrication intervals.

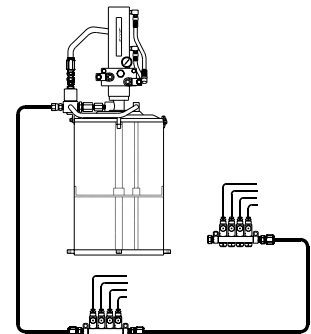

Hydraulic

A complete hydraulically-powered pumping unit for centralized lubrication of individual machines. Usually installed on machinery such as coal mining and earth moving equipment which utilize a hydraulic pressure system. The frequency of the lubrication cycle can be set manually or by mechanical or automatic controls.

Basic Operating Principles of Centro-Matic® Injectors

Each Lincoln Centro-Matic injector can be manually adjusted to discharge the precise amount of lubricant each bearing needs. Injectors are mounted singly at each bearing, or grouped in a manifold with feedlines supplying lubricant to the bearings. In each case, injectors are supplied with lubricant under pump pressure through a single supply line. Two injector types are available: a top adjusting and a side adjusting. Both types can be used in the same circuit; their selection is made on the basis of bearing lubricant requirements.

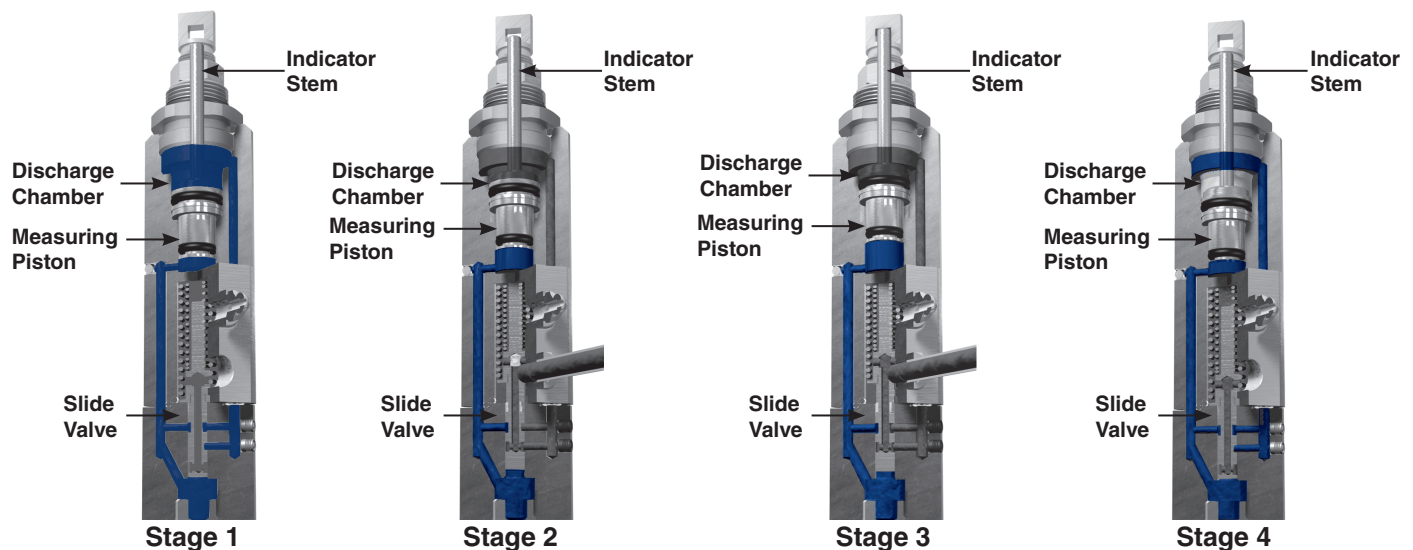

SL-V, SL-V XL

Stage 1—The discharge chamber is filled with lubricant from the previous cycle. Under pressure of incoming lubricant, lubricant is directed to both sides of the measuring piston through the slide valve. The port to the bearing is closed in this position which prevents the measuring piston from moving. The indicator stem will be at its innermost position, having pulled away from the stop in the adjusting screw.

Stage 2—Pressure has built up and has moved the slide valve in position shown. This closes the flow passage to the upper side of the piston (larger diameter) while simultaneously opening the port to allow lubricant to flow out of the injector to the bearing. Pressure from the supply line continues to apply pressure to the lower portion of the measuring piston, which causes a pressure difference across the measuring piston thus allowing it to move upward.

Stage 3—Movement of the measuring piston is shown caused by the pressure on the lower side of the measuring piston dispensing lubricant out to the bearing. The indicator stem will move up against the stop in the adjusting screw when all lubricant has been delivered to the bearing.

Stage 4—As the pressure in the supply line is vented down to 1,000 psi, the slide valve moves back to its rest position. Flow of lubricant to the bearing is closed and simultaneously allows lubricant to flow to the upper (larger diameter) of the piston. The displacement of fluid on the lower side of the measuring chamber is also allowed by the slide valve to flow to the upper side of the piston. The injector is recharged by the residual pressure in the supply line to the upper portion of the measuring chamber.

Centro-Matic® Automated Lubrication Systems

Introduction

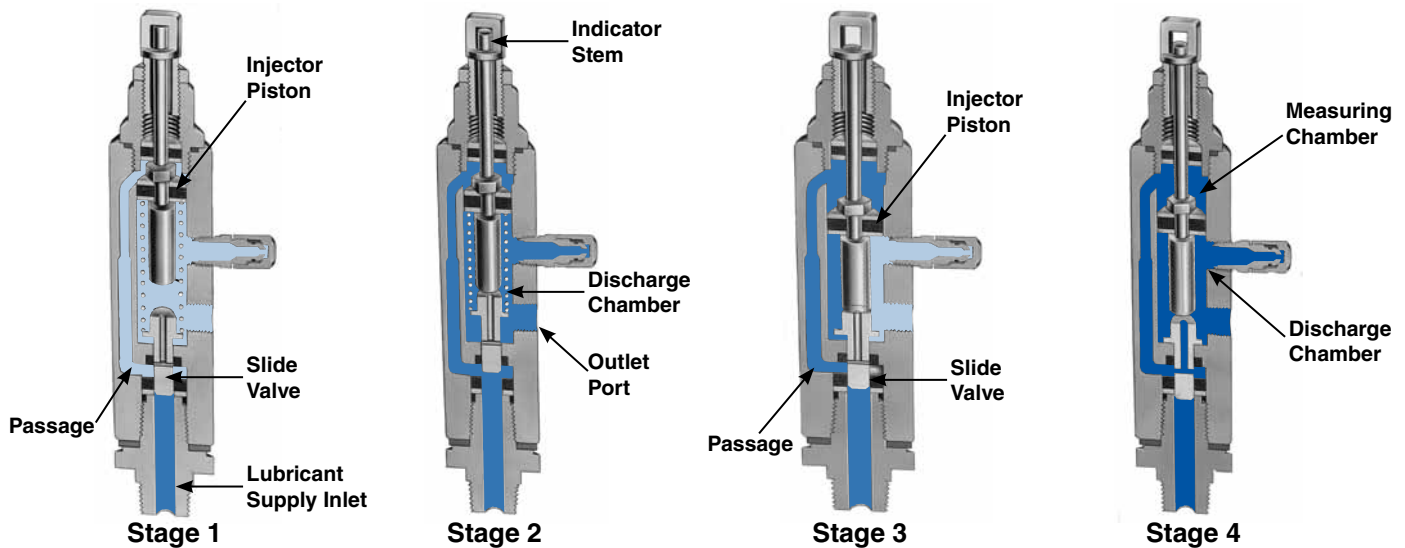

SL-1, -11, -41, -44

Stage 1—The injector piston is in its normal, or rest position. The discharge chamber is filled with lubricant from the previous cycle. Under the pressure of incoming lubricant, the slide valve is about to open the passage leading to the piston.

Stage 2—When the slide valve uncovers the passage, lubricant is admitted to the top of the piston, forcing the piston down. The piston forces lubricant from the discharge chamber through the outlet port to the bearing.

Stage 3—As the piston completes its stroke, it pushes the slide valve past the passage, cutting off further admission of lubricant to the passage. Piston and slide valve remain in this position until lubricant pressure in the supply line is vented (relieved) at the pump.

Stage 4—After pressure is relieved, the compressed spring moves the slide valve to the closed position. This opens the port from the measuring chamber and permits the lubricant to be transferred from the top of the piston to the discharge chamber.

SL-32, -33, -42, -43

Stage 1—Incoming lubricant, under pressure from the supply line, moves the injector piston forward. The piston forces a pre-charge of lubricant from the discharge chamber through the outlet check valve to the feed line.

Stage 2—When the system is vented (pressure relieved), the piston returns to the rest position, transferring lubricant from the measuring chamber to the discharge chamber.

Applications—When it comes to eliminating costly, manual point-by-point lubrication, Centro-Matic systems have proven to be the right solution for many industries and applications. Examples include:

- Paper Converting
- Plastic Processing
- Wood Processing
- Printing
- Packaging
- Textile
- Food & Beverage
- Metalworking
- Material Handling Equipment

