



Capabilities

INFORMATION FROM THE LEADER IN THE LUBRICATION INDUSTRY

Automatic Lubrication Systems for Construction Equipment

Articulated Trucks
Backhoe Loaders
Cold Planers
Compactors
Conveyors:
Crushers/Grinders
Cranes
Excavators
Feller Bunchers
Forest Machines
Hammer/Breakers
Loaders (Wheeled and Track)
Material Handlers
Motor Graders
Multi Terrain Loaders
Off-Highway Tractors

Off-Highway Trucks
On-Highway Trucks
Paving Equipment
Pedestal Breakers
Portable Asphalt Plants
Ready Mix Trucks
Road Reclaimers
Sand Screws
Scrapers
Screens
Skid Steer Loaders
Telehandlers

Trenchers
Underground Mining
Washers
Wheel Dozers
Wheel Excavators
And more . . .

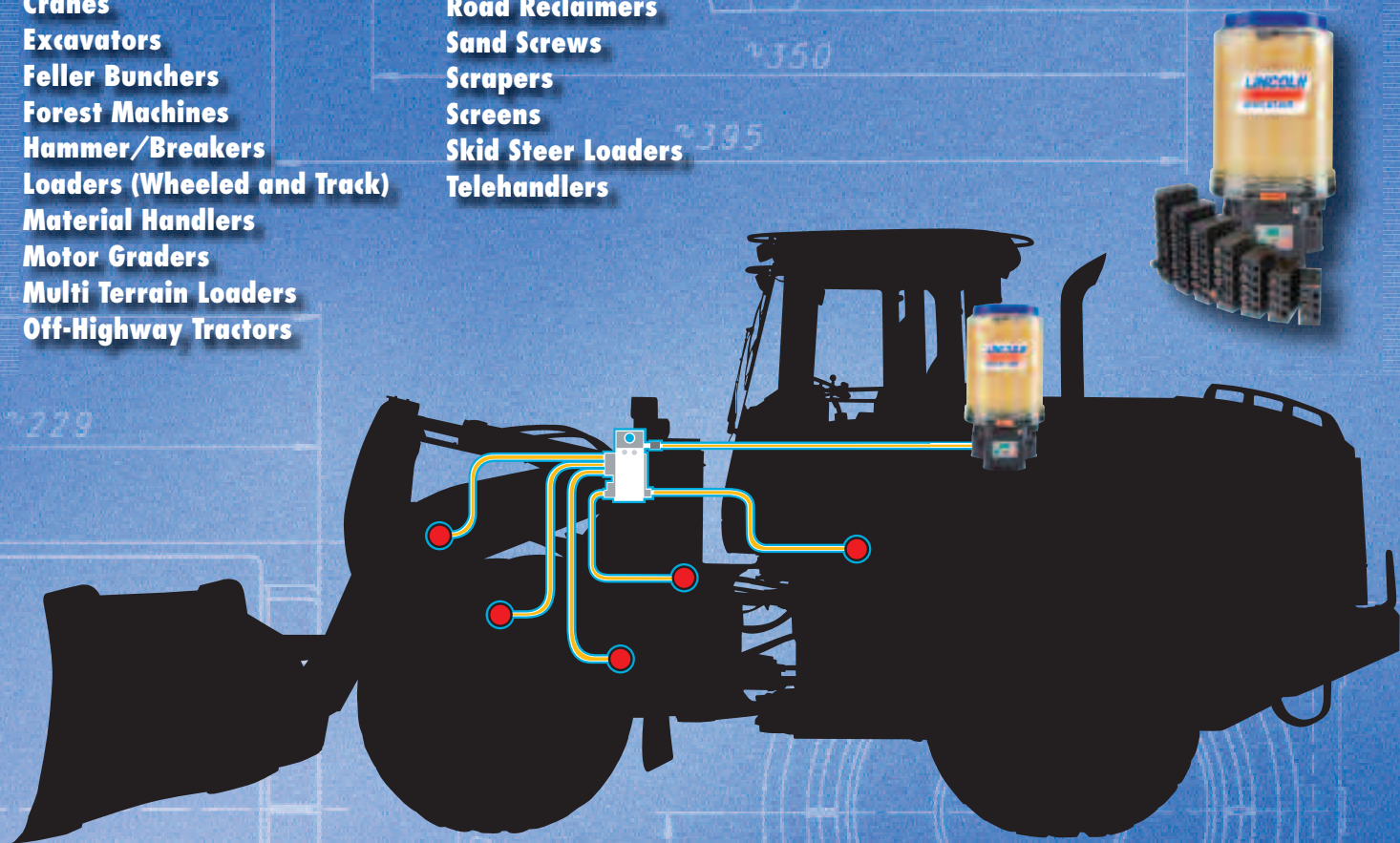

Helping Lower Maintenance Costs
and Improve Productivity

Daily Lubrication is a “Required Maintenance Practice” that’s Vital to the Life of Pins & Bushings

Frequent lubrication not only maintains the proper lubrication film to reduce wear, but also acts as a means to purge the pins and bushings of contamination. If rock dust, dirt, sand and water are allowed to work their way into these components, they will form a “grinding compound” that reduces bearing life dramatically. This will cause downtime and higher maintenance cost.

To do this properly with manual lubrication, it normally takes at least 30 minutes per machine every day.

Daily Manual Lubrication Is Not Easy Due To:

- Bad weather conditions
- Production demands—you don’t want to shut machinery down
- Safety concerns—climbing over machinery
- Logistics—such as lube truck availability and equipment location
- Many bucket and boom pins need to be lubricated in more than one position to evenly distribute lubricant and protect components under heavy load
- Manpower issues—not all employees perform lubrication properly

Failure to lubricate every lubrication point, on every machine, every day, can negatively affect your schedule, your maintenance costs and your “on time” performance.



When manually lubricating a bearing, typically grease is not even spread inside the bushing and is not completely purged



The Cost Of Improper Lubrication

- Increased spending for repairs and parts
- Lost production due to daily manual lubrication and unexpected repairs
- Contamination—wearing down the pins, bushings and other components
- Lower resale value for used equipment
- Waste of lubricant caused by excess lubrication

You Need Automatic Lubrication for Daily and Weekly Lubrication Points

Lincoln's Recommendations

- 1) Use automatic lubrication systems for all your daily and weekly lubrication points.
- 2) Use manual lubrication only for small equipment with few lubrication points or machines with bearings that require extended lubrication intervals (every 250 hours).

Benefits From Automatic Lubrication

- Gain 30 to 45 minutes a day of increased productivity for each machine by lubricating “on the fly.”
- Substantially improve bearing life and reduce repairs by delivering frequent, smaller amounts of grease to each bearing.
- Cut grease consumption by delivering exact amount required.
- Improve safety by eliminating the daily practice of climbing all over machinery to lubricate.
- Proper lubrication no matter the environment or weather conditions.
- Increase resale value of equipment.



The Quicklub® Advantage

Through Lincoln's unique Quicklub system, small, measured amounts of grease are delivered to each bearing at specific time intervals (typically every 10 to 30 minutes) while equipment is operating. This method produces a grease “donut” seal around each pin and bushing . . . which acts as a barrier to keep contamination out. Unlike manual lubrication, grease is spread evenly around the pins and bushings.

How Lincoln Quicklub® Automatic Lubrication Systems Work

System Description

A typical system includes an automated electric pump, metering valves, supply line and feedline hoses, mounting hardware and custom guarding.

Lincoln's Quicklub Pump combines a lubricant reservoir, pump and control system into one unit. Available control options include the ability to notify the operator of system malfunction using a special light and buzzer in the cab.

The metering devices used in Lincoln's system are the Quicklub SSV divider valves. The grease flow created by the pump is proportioned in the SSV divider valve and distributed to each bearing according to their needs.

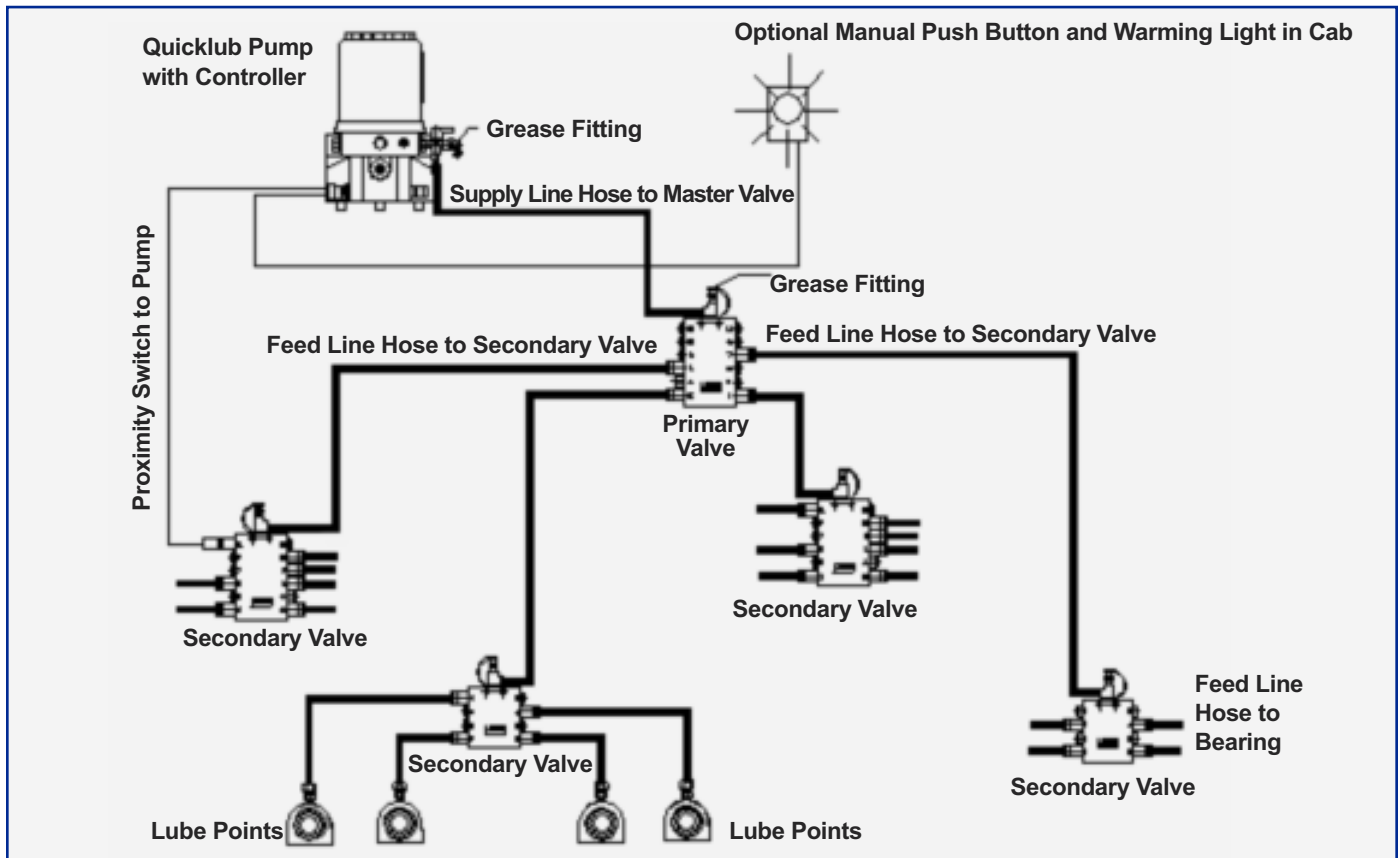

System Operation

1. The Quicklub Pump is actuated automatically by an internal adjustable timer.
2. Grease flow starts and lubricant is delivered to the "Primary Divider Valve" through the supply line hose.
3. The Primary Divider Valve distributes grease in measured amounts to the secondary valves.
4. The secondary valves proportion the grease and deliver exact measured amounts to the bearings according to their specific needs through feed line hoses.
5. Typically, the pump shuts off after receiving a signal from a proximity switch located on a secondary valve. The proximity signal indicates a successful lube cycle. (Some systems do not use a proximity switch. Instead, a built-in timer turns the pump off).

Quickclub® Pump and Divider Valve Features

The Lincoln Quickclub Pump

Designed for the harsh environment of the construction and mining markets, Quickclub pumps are loaded with features:

- Available in 12 and 24 VDC and 120 VAC.
- Capable of dispensing #2 grease (oil systems available).
- Optional low-level alarms and system operation alarms with warning lights in the cab.
- Reservoir (2-, 4-, 8- or 15-liter) can be refilled through a grease fitting, typically every 150 to 300 hours of operation.
- All pumps have high-pressure capability to ensure grease is delivered to each component.
- A blocked lube point can be detected at the pump or in the cab with the optional alarm and warning light . . . a buzzer can be added.
- Pump controls run-time with built-in timer.
- Data Logger models available that store information on system operation history and can be connected to “Product Link®/GPS” to remotely notify if the system requires service.



Quickclub Divider Valves

The heart of the Lincoln System is the Quickclub SSV Divider Valve. These valves utilize unique internal pistons to precisely “divide” the grease flow to ensure each pin and bushing receives the proper amount of lubricant.

- Operating pressures of up to 4,000 psi. The valve delivers grease to every point, even under heavy loads.
- Standard SSV Valves can be “ported” to deliver more grease to specific lube points.
- If the pump is ever damaged, the system can be cycled from the grease fitting on the pump or primary valve.
- Valves are available with cycle indicator pins to provide visual indication of operation.
- With advanced monitoring, a proximity switch sends a signal to the pump when the system has completed a lubrication cycle to each pin and bushing.
- Special Lincoln high-pressure hose (4,000 psi working pressure) is used with the Quickclub fittings that work like a quick-coupler to facilitate system maintenance.

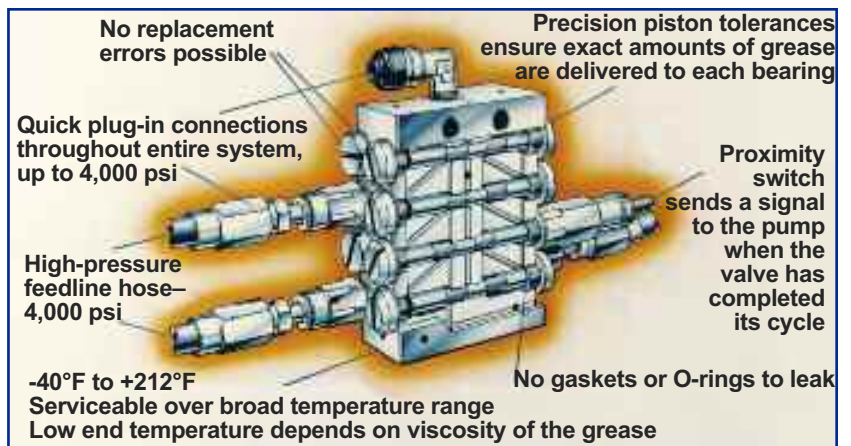

Automatic Lubrication Works for Your Most Challenging Applications

Lincoln Knows How To Tackle The Toughest Situations—Including Excavators

Many equipment OEMs offer Quicklub as a factory installed option. The Lincoln network of qualified distributors can also custom design and install systems on most pieces of equipment... including plant equipment—conveyers, crushers, screens, etc.

High “Impact Areas”

The H-link and bucket can be lubricated automatically with custom guarding installed. The OEM fittings for the stick and bucket connections are relocated to the top side and special guarding is added for protection.



VALVE #3
Serving: H-link and bucket linkage. The valve guard has been added to the H-link.



VALVE #2
Serving:
Bucket cylinder foot pin,
arm link pin, arm cylinder
(rod end), boom arm pin
and arm bucket pin



OEM fittings are relocated to the topside of the stick and bolt-on guards are added



IN-CAB WARNING LIGHT

The optional warning light alerts the operator if the pump reservoir is low or if a lubricant line is blocked. This light also functions as a manual button to initiate a lube cycle.



PRIMARY VALVE

Serving: Secondary valves 1, 2 and 3 as well as right and left boom foot pins



QUICKLUB PUMP

8-liter Datalogger pump with integrated timer, low-level and system alarms



VALVE #1

Serving: Swing circle (2), right and left boom cylinder (head end), right and left boom cylinder foot and arm cylinder foot pin

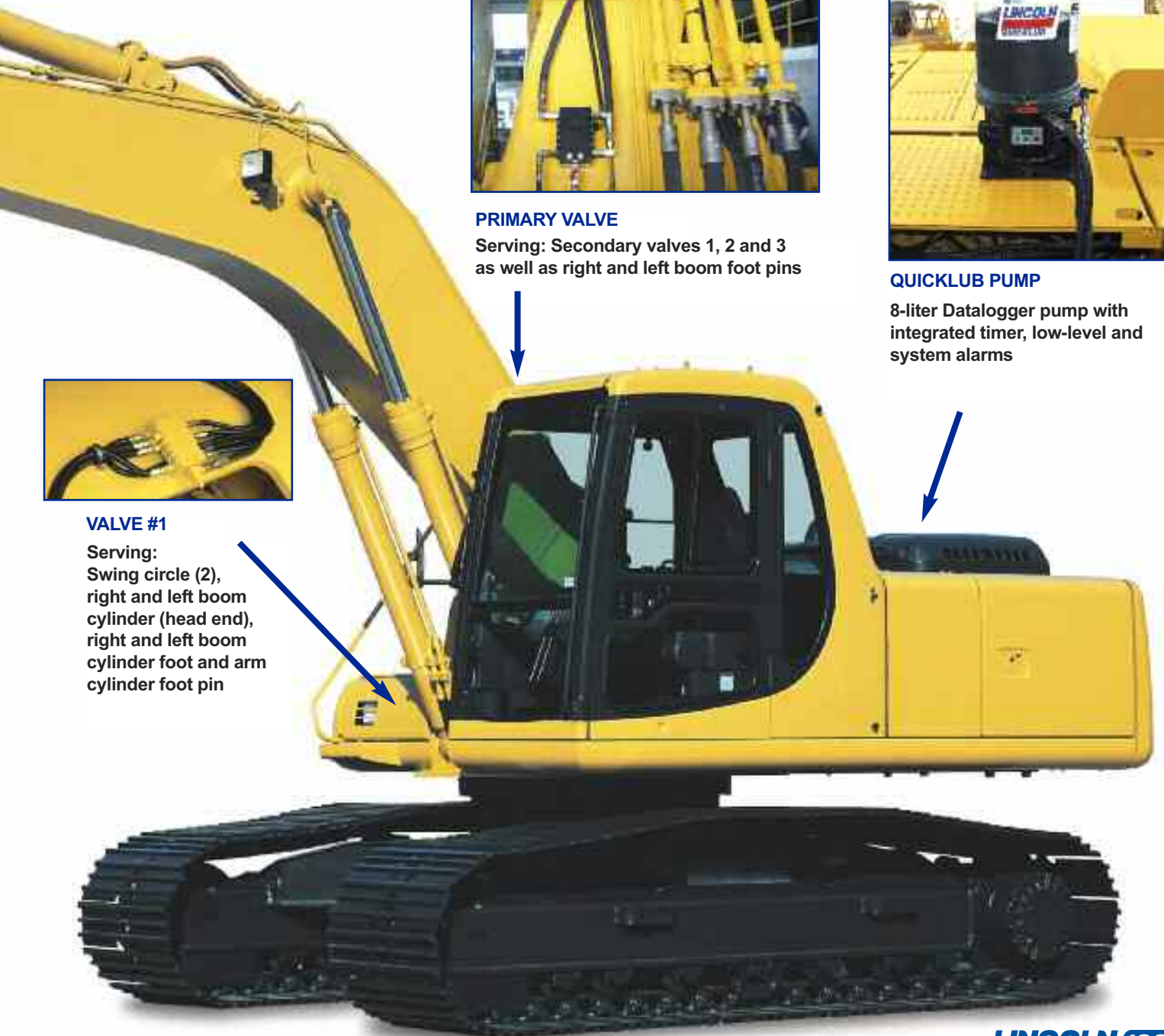

Like Our Solutions for Excavators, Lincoln Offers Custom Systems for All Brands of Wheel Loaders

***Both Factory-Fit and Locally Installed Systems Sold Through
Distribution Are Available***



On this loader, a Quickclub pump is mounted on the operator deck/fender near the cab for ease of visual monitoring and service



Quickclub® metering valves ensure more grease is delivered to high-demand bearings



Ground level reservoir filling is made easy with optional remote fill fitting



Feedline hoses are protected in "high impact" areas with custom bolt on guarding



Lincoln system houses have experience to ensure installations are clean and neat

Lubricate Your Equipment While It Is Running and Significantly Reduce Your Downtime

Haul Trucks Are A Popular Application Due To High Productivity Requirements



Keep both articulating and stiff-framed trucks moving.

Lincoln's automatic lubrication systems create a consistent, properly greased donut that seals out grit and grime from articulating joints, pins and bushings. Lines going to high-impact zones are consistently protected.

Note: The photo on the right shows a Data Logger Pump safely mounted on the deck level. This pump is connected to a "Product Link®/GPS" that will remotely notify if the system requires service.

Demolition Hydraulic Hammers—Keep Your Hammer On The Job

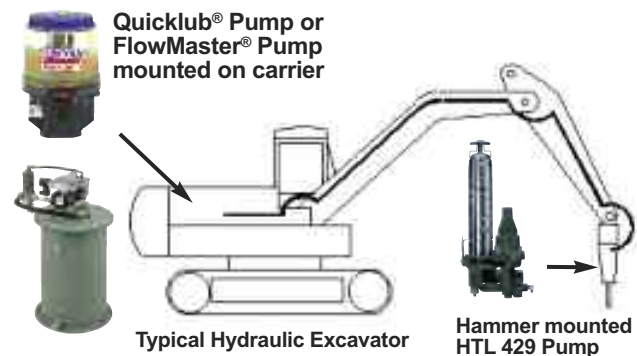

Lincoln is the only company that offers three types of lubrication systems for hammers . . . even one that mounts directly on a hammer.

Other Equipment



Quicklub system installed on a ready mix truck

Quicklub divider valve mounted on a milling machine

Lincoln distributors have experience installing systems on many types of mobile and stationary construction equipment.

Other common applications include:

- Graders, scrapers, dozers
- Drills (horizontal and vertical)
- On-road trucks paving equipment (milling machines)
- Trenchers
- Crushers, screens, conveyors
- Ready mix trucks
- Cement pumps
- Recyclers
- Backhoes
- And many more

The Single Source for All Your Lubrication Needs

Centro-Matic® Automatic Lubrication (For Larger Mining Equipment)

The system trusted by the mining industry world-wide is the same system you need for your largest equipment. Major original equipment manufacturers install Centro-Matic systems in their factories to ensure their customers get the best value and longest service possible. The famous SL-1 and the new SL-V injectors provide consistently reliable, large doses of grease to all critical lubrication points. Our latest FlowMaster® pumps drive these system using either DC electric or hydraulic power sources.



State-Of-The-Art Lube Truck

Many contractors rely on the services of a good lube truck to maintain equipment in the field. Our specialty distributors can help you build and maintain the best lube trucks in the business. They feature on-board pumps, reels, control devices and accessories that make quick work of lubricating equipment on-site.



Complete In-Shop Maintenance Equipment

Our comprehensive line of performance-proven pumps, hose reels, controllers, grease guns and fluid inventory control systems offers you everything you need to build a fully functional lube station. From the tools used to pump and dispense to the ones designed to accurately track the use of fluids, oils and greases, Lincoln offers dependable solutions when designing your vehicle maintenance shop.



A Broad Range Of Pumps

Whether you're pumping grease, oil, antifreeze, windshield washer fluid or other vital solutions, Lincoln has the medium- or high-pressure pump to get the job done. Choose from our new series of PMV pumps and PowerMaster® reciprocating pumps, diaphragms and transfer pumps, bulk oil systems, plus all the accessories you'll ever need.



Hand-Held Lubrication

Using a grease gun may never be the same. Our 14.4-volt, battery-powered PowerLuber® outperforms traditional lever-action grease guns by generating as much as 7,500 psi of working pressure:

- Each battery dispenses two tubes of grease
- Convenient whip hose allows for easy access on hard-to-reach points
- Comfortable trigger makes one-hand operation easy

If you need extended battery time, order the 1444 in a case with two batteries, or select the 1415 battery charger that plugs into the accessory/ lighter receptacle of your construction machine.

Lincoln also carries a full line of the most dependable hand-operated grease guns in the business.



A Lincoln Quicklub® System Pays for Itself in Less than a Year

Calculate the return on your investment

Annual Costs to Manually Lubricate a Mid-size Loader

Labor	Typical	Your Anticipated Benefits
30 minutes per 8-hour shift X \$30/hour X 250 days	\$3,750.00	_____
Lost Production 30 minutes per 8-hour shift X \$95/hour X 250 days	\$11,875.00	_____
Manual Lubrication Cost	\$15,625.00	_____

Annual Costs to Repair Failed Components

Replacement Pins and Bushings 2 Pins X \$500.00 each	\$1,000.00	_____
Repair Labor One Person X \$65.00 X 2 Repairs X 6 hours each	\$780.00	_____
Lost Production 2 Repairs X 6 hours each X \$95.00/hr.	\$1,140.00	_____
Repair Cost	\$2,920.00	_____
Annual Manual Lubrication Cost	\$18,545.00	_____

Estimated Savings with a Lincoln Quicklub Automatic Lubrication System

	% Savings	\$ Savings	
Labor and lost production to manually lubricate	95%	\$ 14,843.75	_____
Parts, labor and lost production to repair failed components	50%	\$ 1,460.00	_____
Total Annual Savings		\$ 16,303.75	_____

System Cost and Return on Investment

Typical installed Quicklub® System cost for a loader with Data Logger Pump	\$ 7,800.00	_____
--	-------------	-------

Return on Investment

System Cost / Annual Savings X 12 Months = R.O.I.

\$7,800.00 / \$16,303.00 X 12 Months =	5.7 Months Pay Back (ROI)	_____
--	----------------------------------	-------

System cost will vary based on options, local labor costs, and location of installation.



Celebrating Our First Century In Business



Lincoln's Global Distribution Network

Whatever the service—evaluating your lubrication needs, installing custom-engineered systems, supplying top quality accessories or selling manual lubrication components, your Lincoln distributor gives you the best value on the best products.

Local Distribution is Here to Help!

Our distribution system houses offer the highest level of expertise and service levels:

- Custom design systems for your equipment
- Custom guarding packages to protect feedline hoses
- Turn-key systems for new and used equipment
- On-site installation, service and maintenance contracts
- Training for your operators and maintenance personnel
- Large backup parts inventory



Visit our web site www.lincolnbuilds.com for your nearest authorized sales and service representative and international contact information.

Contact Your Local Distributor



Celebrating Our First Century In Business

Lincoln Industrial Corp.
One Lincoln Way
St. Louis, MO 63120-1578

Phone (314) 679-4200
Fax (314) 679-4359
www.lincolnindustrial.com

Form 442989 (12/09)
© Copyright 2009
Printed in U.S.A.