

Fluid Handling

Lincoln's Model 3614 simplifies your Used Oil Handling needs

Features

◆ EASE OF USE

- Extra Large 18-inch Offset Bowl easily catches fluid without repositioning the tank
- Telescopic (44 to 72 inch range) Bowl Height Adjustment allows for greater flexibility
- Low Profile Design is extremely stable and easy to maneuver
- Large 20-Gallon (75 L) capacity averages 15-20 vehicles before tank evacuation
- Special Valve Design allows evacuation with bowl set at any height

◆ DURABLE

- Heavy Gauge Steel Construction
- Protected Sight Gauge for easy fluid level monitoring

◆ INCLUDES

- Fixed Air Regulator allows use of standard shop air during evacuation
- Tank Pressure Relief Valve for added safety
- Reinforced Discharge Hose
- Hose Hanger built into bowl



Used Oil spills create both environmental and safety hazards.

The new model 3614 simplifies the used fluid evacuation process by allowing the technician to drain, transfer and evacuate used oils with virtually no chance of spillage.

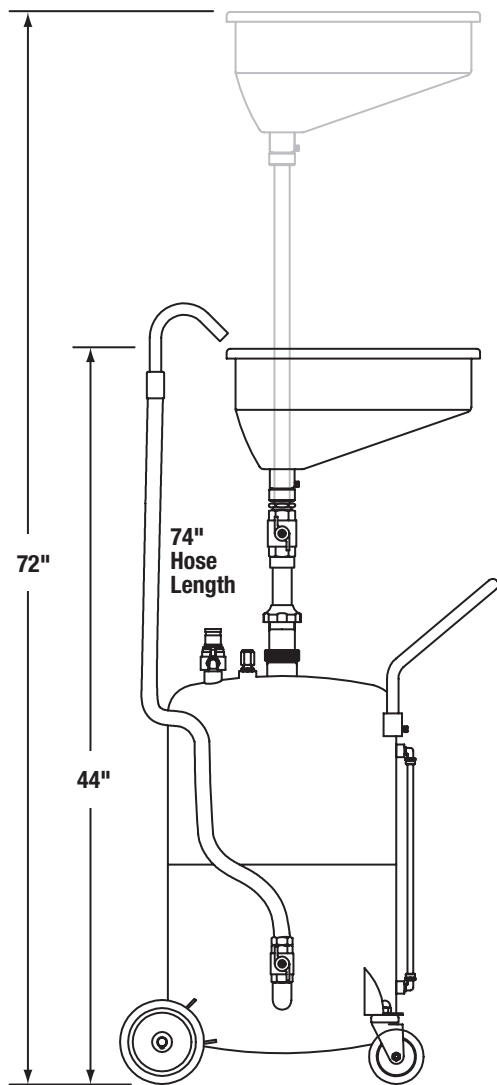

The offset bowl reduces the risk of spillage and eliminates the need to reposition tank.

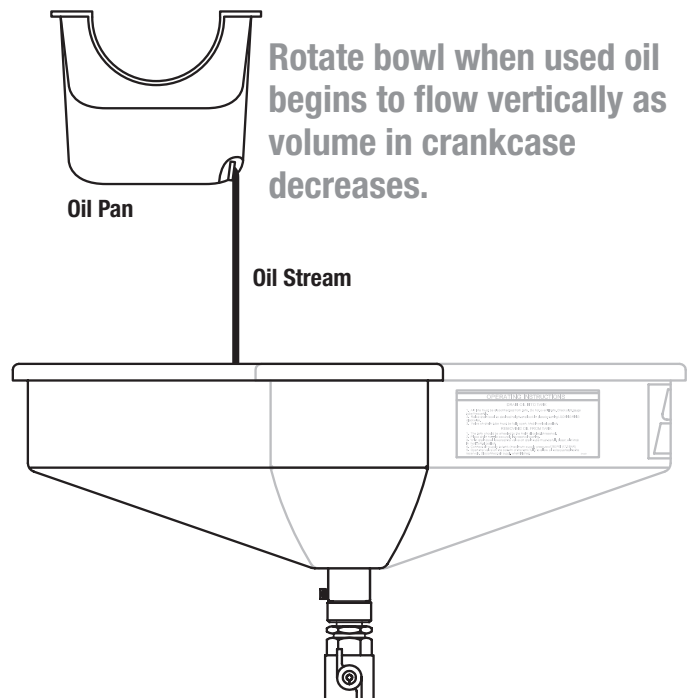
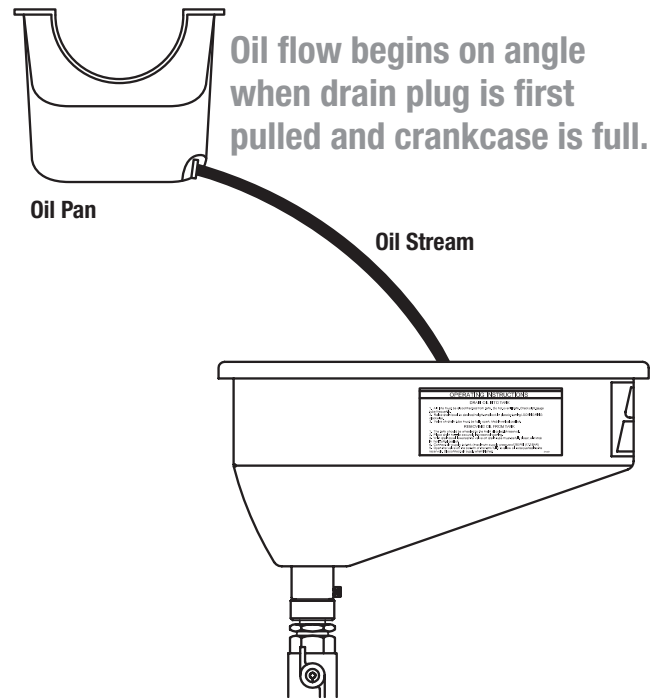

◆ SPECIFICATIONS

- Capacity: 20 Gallon / 75 Liter
- Weight : 65 U. S. Pounds / 29.5 Kg



Lincoln Industrial Corp.
One Lincoln Way
St. Louis, MO 63120-1578

Phone 314-679-4200
Fax 314-679-4359
www.lincolnindustrial.com

Form 442996 (03/05)
© Copyright 2005
Printed in U.S.A.