

## FlowMaster™ Hydraulic Pump Rotary-Driven, Powerful and Versatile

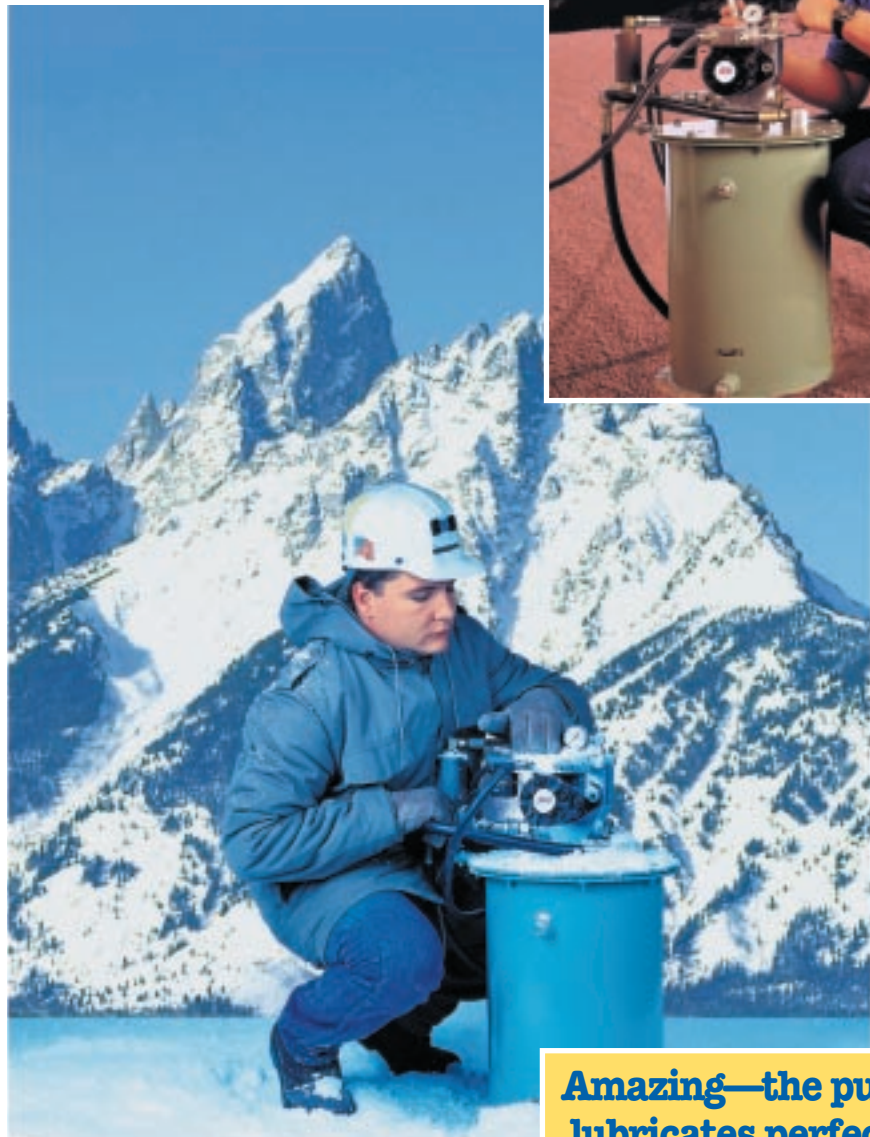

**Amazing—the pump lubricates perfectly in arctic cold and desert heat.**

### In This Issue:

FlowMaster Hydraulic Pump *Cover Story*

60-pound Container Improvement *pg. 5*

POWER-LUBER™ Grease Gun *pg. 6*

High Temperature Injector Seals *pg. 8*

Metric Injectors *pg. 8*

SL-1 Six-Station Injector *pg. 8*

Lincoln Industrial Introduces

# FlowMaster

## A HIGH-PERFORMANCE PUMP\* that Works in the Severest Conditions

The company that provides the best automated lubrication systems and industrial thick-fluid transfer pumps has scored a technological breakthrough with FlowMaster, a new high-performance pump that lubricates in the severest conditions. FlowMaster—a rotary-activated reciprocating hydraulic pump—will change the field of lubrication.

The versatile FlowMaster pump works with Centro-Matic, Quicklub, Modular Lube, Helios and Duo-Matic systems.



### A New Generation of Lubrication Pumps

Lincoln Industrial's new pump "changes the rules" of the lubrication game. It's so compact, it fits almost anywhere. It's versatile because its unique rotary drive and control manifold let users adjust the pump to fit their applications exactly. It doesn't need electric power to run (it only requires an electric switch to start). And it doesn't need air, because the pump is designed to work off a hydraulic system. That means construction companies, mining operations and many other industries can confidently install the new FlowMaster pump on trucks, excavators, loaders, draglines, conveyors, crushing machines, drills, and many other applications.

### High Performance in the Arctic or the Desert

Extreme temperatures won't stop Lincoln Industrial's new pump. It has passed rigorous tests in both arctic and desert conditions. Capable of developing 6,000 PSI, the powerful pump easily puts out 10 cubic inches per minute of No. 2 grease at temperatures below 0°F (-20°C) at hydraulic input of 2 gallons per minute.

The pump works well with high-viscosity grease (NLGI 2 and above) at low temperatures because its pump tube has a special pre-charge chamber and a reciprocating cylinder designed to allow better priming. An inlet ball check reciprocates with the pump cylinder allowing better grease flow to the pump chamber.

**Grease Output vs. Hydraulic Input**  
1,000 psi back pressure and NLGI #2 grease

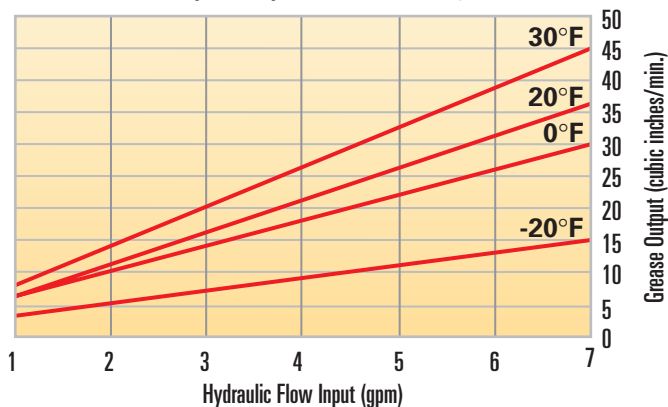

The more hydraulic input that's available, the more grease output the FlowMaster pump can generate.

\* Foreign and U.S. patents pending

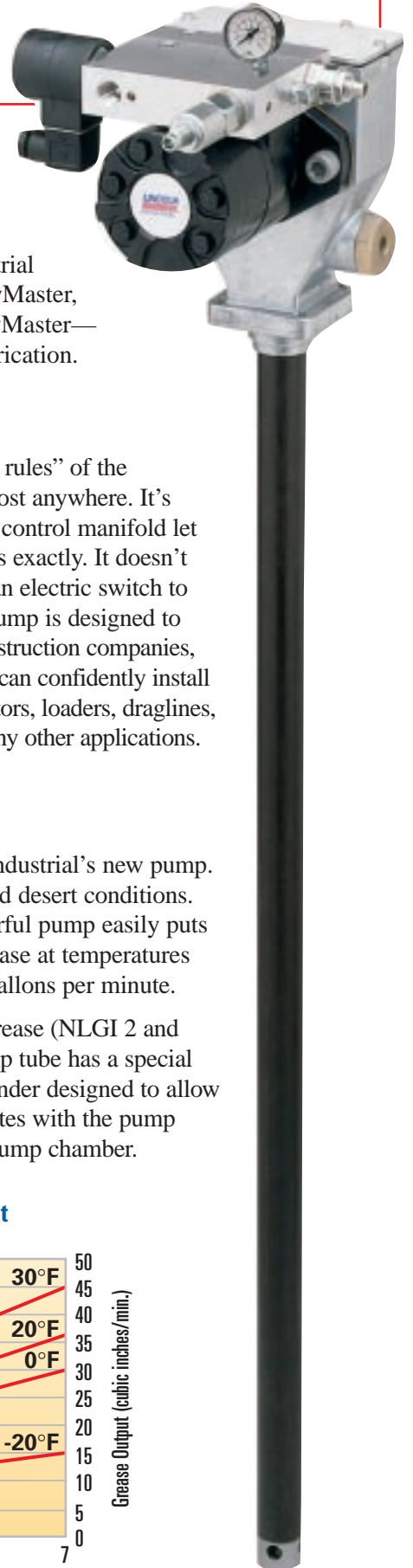



The new FlowMaster pump will do the job for the mining and construction industries at preparation plants and on excavators, wheel loaders, stone crushers and lube trucks.

### Built-in Flexibility

The new FlowMaster pump offers users almost unlimited opportunities. Its control manifold adjusts the amount of lubricant and the pressure required for each application. The more hydraulic input available, the more output the pump can generate. The pump's controls match a machine's hydraulic output to the requirements of its lubrication system.

### Wide Range of Applications

Designed to work with Lincoln Industrial's Centro-Matic single-line, parallel systems, Quicklub and Modular Lube progressive systems, and with its Helios and Duo-Matic two-line systems, the FlowMaster pump works well in an extensive range of applications because of its variable output capability. With its impressive output range (7 to 45 cubic inches per minute), the revolutionary pump handles everything from small mobile equipment with low lubricant requirements to machinery with the highest lubricant demands.

The new FlowMaster pump also does one other thing. It shows that Lincoln Industrial is a problem-solver, providing its partners with innovative proactive products that meet their needs.

Integrated manifold contains:

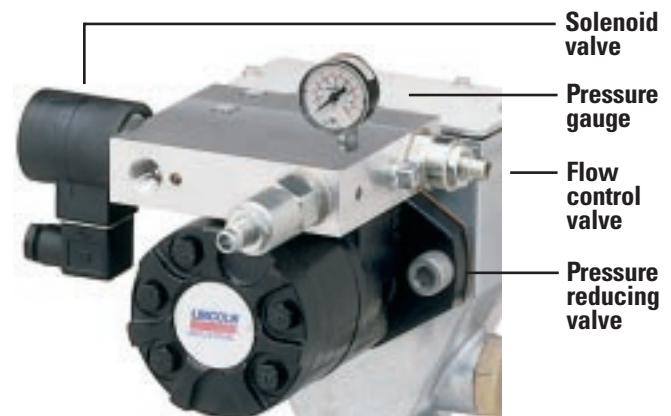

An integrated manifold makes the FlowMaster pump extremely adaptable.

## Features & Benefits

- ◆ High-performance pump that works in the arctic or the desert
- ◆ Integrated control manifold to adjust the amount of lubricant and the pressure
- ◆ Adjustable output from 7 to 45 cubic inches per minute

# FlowMaster Product Data

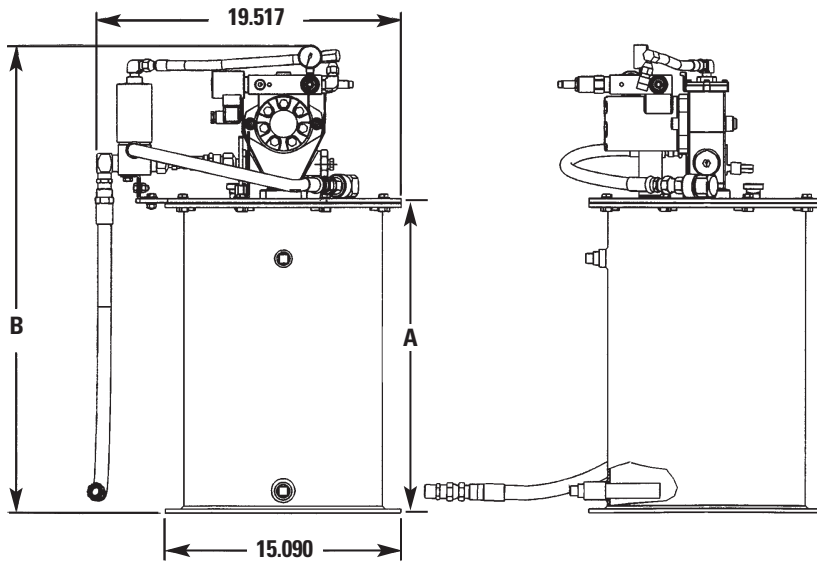

Dimensions of pump assemblies

## Pump Performance and Specifications

Supply inlet hydr. pressure, max.	3000 psig (200 bar)
Operating inlet hydr. pressure	300 to 420 psig (20 to 32 bar)
Hydraulic inlet flow	Up to 7 gpm (28 l/min)
Pump ratio with manifold	9:1 at low inlet pressure (300 to 350 psi/20 to 25 bar) and low inlet flow (below 2 gpm/7 lpm) pump ratio approaches 11:1 ratio at higher inlet pressure and flow
Operating temperature	-20° to +150°F (-10° to +65°C)
Operating voltage	24 VDC
Hydraulic inlet port	3/8" NPTF
Tank return port	3/8" NPTF
Pump outlets	1/4" NPTF
Max. hydraulic fluid temp.	130°F (55°C)
Weight	36 lbs (16kg)

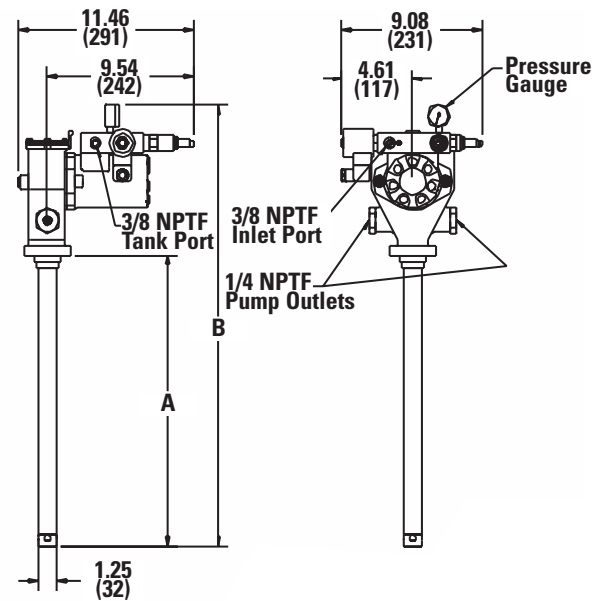

Dimensions of pumps

## Available Models

Model	Description	Dimension A in. / mm	Dimension B in. / mm
85487	60 lb. pump assembly for Centro-Matic	19.90 / 505	29.70 / 743
86258	60 lb. pump assembly with low level and follower plate for Centro-Matic	19.90 / 505	29.70 / 743
85491	60 lb. drum pump assembly with low level and follower plate for Modular Lube and Duo-Matic	19.90 / 505	29.70 / 743
85482	Pump for 400 lb. drum (55 gallon)	34.00 / 864	43.81 / 1113
85480	Pump for 120 lb. drum (18 gallon)	27.50 / 699	37.31 / 948
85481	Pump for 60 lb. canister (8 gallon)	19.00 / 483	28.81 / 732
85483	Pump for 35 lb. pail (5 gallon)	13.69 / 348	23.50 / 597
252725	Follower plate for 35 lb. unit	—	—
85489	Follower plate for 60 lb. unit	—	—
85490	Low level assembly for 60 lb. unit	—	—

# Lincoln Industrial's New 60-Pound Reservoir The Tough Get Tougher

Improving our 60-pound lubrication reservoir only means one thing—the tough just got even tougher.

We made 12 improvements, including an enhanced follower plate, a thicker rubber seal and extra-thick plating (see drawing for complete list). An important improvement is the thick mounting ring with twice as many mounting holes. It resists loosening and withstands the severest vibration. The new follower plate wiper acts as a “squeegee”, removing the lubricant from the sides of the reservoir as its travels downward. This scraping action reduces lubricant waste by eliminating buildup on the top of the follower plate. The new 3/4" NPT fill inlet is upgraded from a 3/8" inlet and cuts filling time in half. The new reservoir works with Lincoln Industrial's new FlowMaster hydraulic pump and the air-operated pump. Mobile construction and mining equipment—from medium and large loaders and excavators to haul trucks, crushers and more—have a partner in our new 60-pound reservoir they can count on even more than before.

The reservoir works with both hydraulic and air pumps.



## Air-Operated Models with New Bucket

Model	Description	Height
84050	60 lb. pump assembly for Centro-Matic	31"
85460	60 lb. pump assembly with low level and follower plate for Centro-Matic	31"
249608	Low level assembly for 60 lb. unit	

## Hydraulic Operated Models with New Bucket

See page 4 for listing

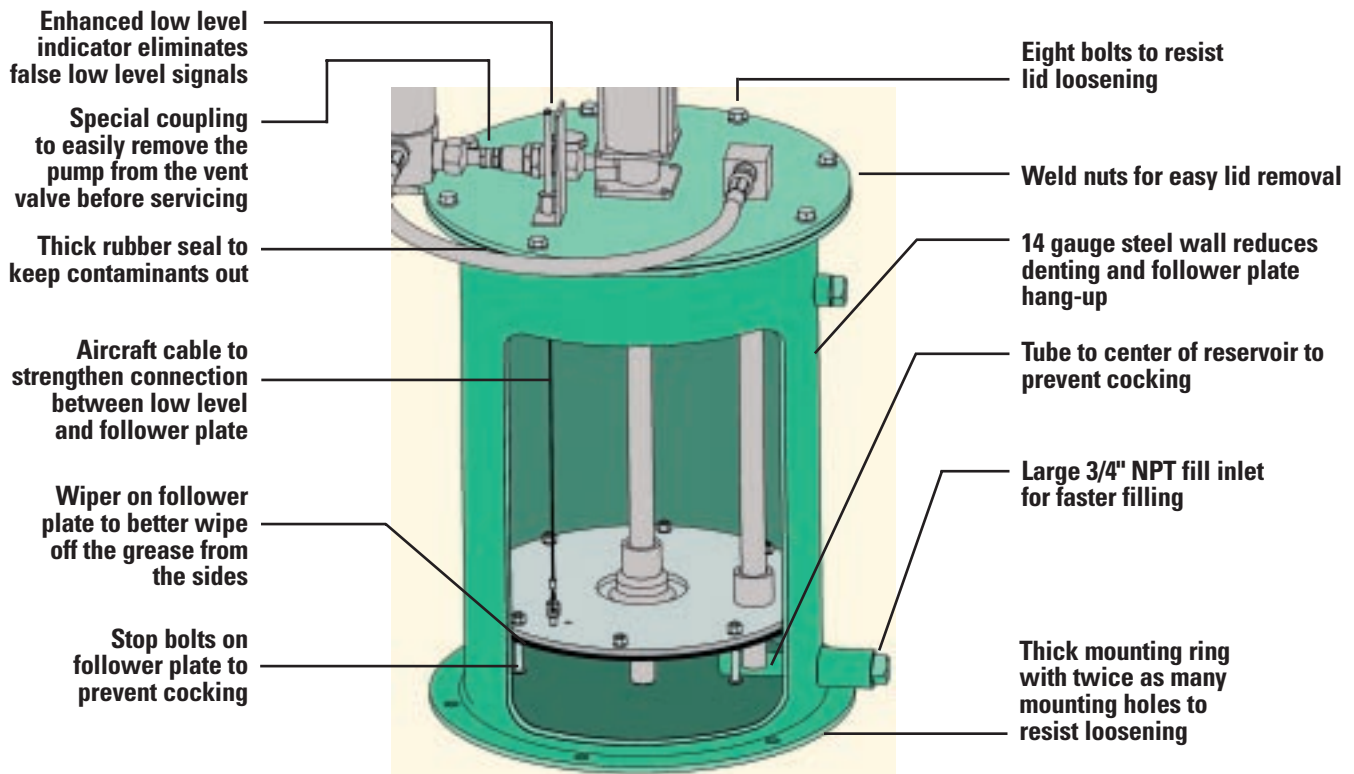

# Introducing **POWER-LUBER™**

## Lincoln Industrial's 12-Volt Cordless Rechargeable Grease Gun

Fast, convenient, powerful, reliable, versatile—Lincoln Industrial's rugged, easy-to-use POWER-LUBER 12-Volt Cordless Rechargeable Grease Gun is the ultimate hand-held lubrication tool. The revolutionary POWER-LUBER is the first lightweight, affordable cordless battery-powered grease gun that doesn't require muscle power. With just a simple pull of its trigger, the POWER-LUBER provides the portable lubrication solution for numerous industries. Whether it's a truck, a mobile machine used in construction, a hard-to-reach spot in a mine, a key manufacturing process, or an expensive agricultural machine, the POWER-LUBER grease gun is the lubrication answer.

The POWER-LUBER is the best portable grease gun because it holds up to the real-world needs of people and machines working in the world's harshest environments—and then comes back for more. At the very least, a grease gun should deliver results again and again and be easy to use. The POWER-LUBER excels on both counts—and a few more.

**The  
Ultimate  
Grease  
Gun**

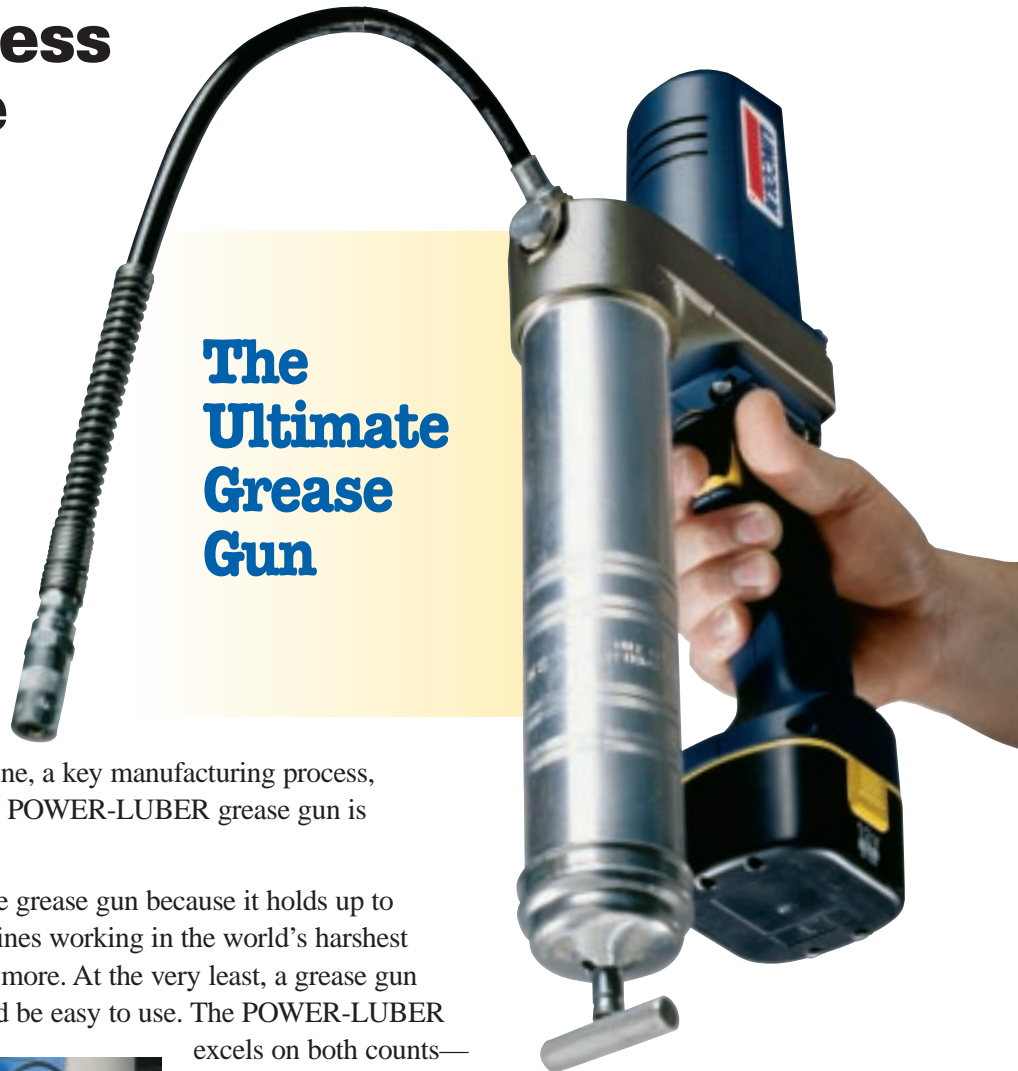

It's the lightest portable grease gun (only 7 ¼ lbs. with battery) and easy to carry because of its balanced design, but the POWER-LUBER is heavy-duty on the job. With a powerful 12-volt motor, it delivers lubricant effectively under high pressure. It's rated at 6,000 psi (414 bar), but the POWER-LUBER can actually deliver as much as 7,500 psi (517 bar). It works a long time on each charge of its high-capacity 12-volt battery. And its 3-way loading makes the POWER-LUBER the most versatile grease gun anywhere. You can change new grease cartridges, bulk fill with a pump, or load the gun with suction—all with ease.

**The POWER-LUBER is used in construction, mining, manufacturing, farming and transportation, where automated lubrication systems are not yet installed, or to cycle single-point lubrication systems.**

## Features & Benefits

- ◆ **Balanced design for ease of use**
- ◆ **Continuous operation for faster service**
- ◆ **High pressure delivery for effective lubrication**
- ◆ **High-capacity 12-volt battery for extended operation**
- ◆ **Powerful 12-volt motor for greater efficiency**
- ◆ **3-way loading for versatile refilling**

But there's more. The POWER-LUBER is great for filling and cycling single-point centralized lubrication systems. It's an ideal tool for filling reservoirs of automated lube systems such as Lincoln Industrial's PL2000. And during normal greasing, the grease gun's high pressure opens most stuck fittings. In fact, the POWER-LUBER is so reliable that when a properly-charged gun can't get a fitting unstuck, it means the fitting probably needs replacement.

The POWER-LUBER has many ease-of-use features. Batteries push in and come out easily, and the battery charger "communicates" its status. The red light means a battery is "fast charging." When the green light glows (in only one hour!), the battery is charged—and stays that way—until it's ready for use. And with no air hose or power cord to get in the way, using the POWER-LUBER is simplicity itself.

Lincoln Industrial and its industry-leading, world-wide distribution system supply everything the POWER-LUBER needs. The Model 1240 comes with a 110-volt charger, a nickel-cadmium rechargeable battery, and a 30-inch spring-guarded hose. Customers can upgrade with a second battery and a custom case.

Lincoln Industrial has been solving lubrication problems for nearly a century. The POWER-LUBER is just the latest in a long line of lubrication solutions from Lincoln Industrial. It's the grease gun you can rely on to keep things running profitably.

### Model 1240



- Comes complete with:
- Model 1210 110-volt charger
  - Model 1201 12-volt ni-cad rechargeable battery
  - Model 1230 30" spring guarded whip hose
  - Packaged in a carton



### Model 1242



- Comes complete with:
- Model 1240
  - Packaged in a custom carrying case, designed to hold two optional grease cartridges.

### Model 1244



- Comes complete with:
- Model 1240
  - Second 12-volt ni-cad rechargeable battery
  - Packaged in a custom carrying case, designed to hold two optional grease cartridges.

### Specifications

- 12V DC battery powered grease gun
- 3 oz/min flow rate
- 6000 psi (414 bar) rated
- 14 oz. capacity reservoir tube
- 1 hour fast charger
- 1,300 mAh high capacity battery pack

### Accessories

Model 1201	Battery
Model 1218	Whip hose assembly (18")
Model 1224	Whip hose assembly (24")
Model 1230	Whip hose assembly (30")
Model 1236	Whip hose assembly (36")
Model 5849	360° Lube adapter
Model 5859	Angle lube adapter
Model 5852	Replacement grease coupler
Model 82784	Needle nozzle

Lincoln Industrial invented and still has the lubrication industry's best injectors. We apply the same innovation to meeting our customers' needs, so it's no surprise that three new injector developments provide our customers with solutions—and make the best better.

# Lincoln Industrial's New **INJECTORS** Meet Customer Needs

## New Metric Injectors Offer Worldwide Convenience

Due to increasing demand from international customers, Lincoln Industrial created its new Metric Centro-Matic Injectors. With the same proven design as our U.S. standard injectors, the new metric versions of our popular small grease and oil injectors feature metric ports. Any surface that needs a wrench is metric. It's more convenient for customers in most of the world, and easier to maintain because there's no need for a second set of wrenches or adapters. SL-32, 33 and 42 Series specifications can be found in the Centro-Matic catalog.



Metric parts are shown in yellow.

## Dimensional Information

Oil SL-42	Grease SL-33	Grease SL-32	Out-lets	Connections		Dim. A		Dim. B	
				Inlet	Outlet	in.	mm	in.	mm
85352-1	85351-1		1	1/8" BSPP (F)	6 mm O.D. Tube Connection	1-1/8	29	1-5/8	41
85352-2	85351-2		2			1-7/8	48	2-3/8	60
85352-3	85351-3		3			2-5/8	67	3-1/8	79
85352-4	85351-4		4			3-3/8	86	3-7/8	98
85352-5	85351-5		5			4-1/8	105	4-5/8	118
85352-6	85351-6		6			4-7/8	124	5-3/8	137
	85353-1		1			1-1/4	32	1-3/4	44
	85353-2		2			2	51	2-1/2	64
	85353-3		3			2-3/4	70	3-1/4	83
	85353-4		4			3-1/2	89	4	102

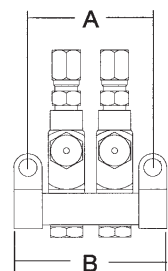

## SL-1 Six-Station Injector Manifold

The SL-1 Six-Station is a perfect example of Lincoln Industrial meeting a customer need. Two major OEMs—Caterpillar and Bucyrus—had several six-point lubrication clusters on their machines. They could use Lincoln Industrial injectors in combinations (5+1, 4+2, 3+3), but a six-station manifold would be ideal. Our solution, the SL-1 Six-Station, not only installs more quickly, it requires less plumbing and space, and it's compatible with our SL-32 and SL-33 injectors. The specifications of Series SL-1 model 81770-6 can be found in the Centro-Matic catalog.

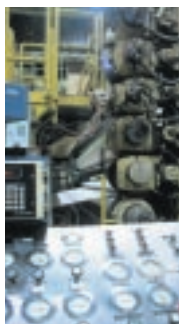
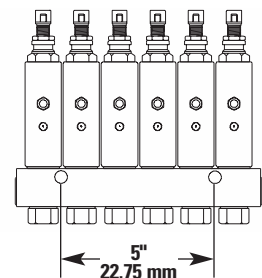

## Centro-Matic High-Temperature Injectors

With their new high heat-tolerant seal composite, Centro-Matic High Temperature Injectors work with greases of all types at up to 300°F (150°C). The new injectors are good “under the hood” on the wet end of a paper mill or in other high temperature or severe applications, but they really shine when aggressive lubricants (like synthetic oils and greases) attack injector seals at higher temperatures.

Model No.	Model
85451	SL1-1
85452	SL1-2
85453	SL1-3
85454	SL1-4
85455	SL1-5
85456	SL1-6

### SOLUTIONS

is a magazine for Lincoln Industrial customers.

Please direct ideas, comments or questions to:

Lincoln Industrial  
Marketing Communications,  
Tel: 1-314-679-4255 or 4256,  
Fax: 1-314-679-4359  
www.lincolnindustrial.com.



One Lincoln Way  
St. Louis, MO 63120-1578  
USA

Phone 1-314-679-4200  
Fax 1-314-679-4359  
www.lincolnindustrial.com

Form 442885  
© Copyright 1999  
Printed in U.S.A.

