

Innovations in Pump Technology

In This Issue:

FlowMaster® Product Line:

- 120/230 VAC Electric FlowMaster *pg. 2*
- 24 VDC Electric FlowMaster *pg. 4*
- Hydraulic FlowMaster *pg. 6*

Ultrahigh-Pressure Pump Tube

- Models 85304 & 85305 *pg. 7*

PileDriver® III

pg. 8

Pressure Primer

- Model 1735 Redesign & Upgrade *pg. 11*

Thermal Pressure Relief Device

pg. 12

Lincoln's line of popular pumps, used in the toughest applications, have been expanded and enhanced to meet our customers' changing needs.

FlowMaster® Powers Up!

Plug It In!

The high-performance FlowMaster product line is a new generation of pump technology. Compact and versatile, its unique rotary drive and modular gear set let you adjust the pump to exactly fit your application. And now you can run it with an AC voltage, DC voltage or hydraulics.

New 120/230 VAC Electric FlowMaster

- Durable
- Flexible
- Cost-effective

Now you can save the cost of air and plug in our new 120/230 VAC FlowMaster pump. Convenient and powerful, the 120/230 VAC FlowMaster pump allows you to tap into your AC power source and pump grease from a 120 lb or 400 lb drum. Rely on it to drive your automated lubrication systems such as Centro-Matic®, Mod Lube®, Quicklub® and Two-line.

Accessories

Description	120 lb	400 lb.
Follower plate	85492	270982
Drum cover	85474	85475
Vent valve assembly:		
120 VAC	85662	85663
230 VAC	85660	85661
Strainer	272180	272180

Specifications

	Model 85589	Model 85588
Pump size	120 lb.	400 lb.
Pump output		24.5 in ²
Operating temperature range	-40° to +150°F (-40° to +65°C)	
Operating voltage	120/230 VAC	
Pump outlets	¼" NPTF	
Motor	½ HP	
Current draw		
120 VAC	1 to 4.6 amps depending on backpressure	
230 VAC	.5 to 2.4 amps depending on backpressure	

Markets and Applications

Markets include heavy industry such as mining, steel and paper; and general industry such as food/beverage, automotive and packaging.

The pump can be used for large mining machinery such as shovels, conveyors and drag lines as well as ball mill applications—a perfect companion to airless spray systems.

Steel mills rely on lubrication systems throughout their plants but don't always have compressed air available where pump stations need to be located.

Paper mills are tough environments with large wet- and dry-end lubrication systems on paper machines but often have a poor quality air supply.

General industry has been asking for an AC pump to simplify installation of lubrication systems used in all types of manufacturing facilities.

Product Description

The motion created by the electric rotary motor is converted into reciprocating pump motion providing an efficient flow.

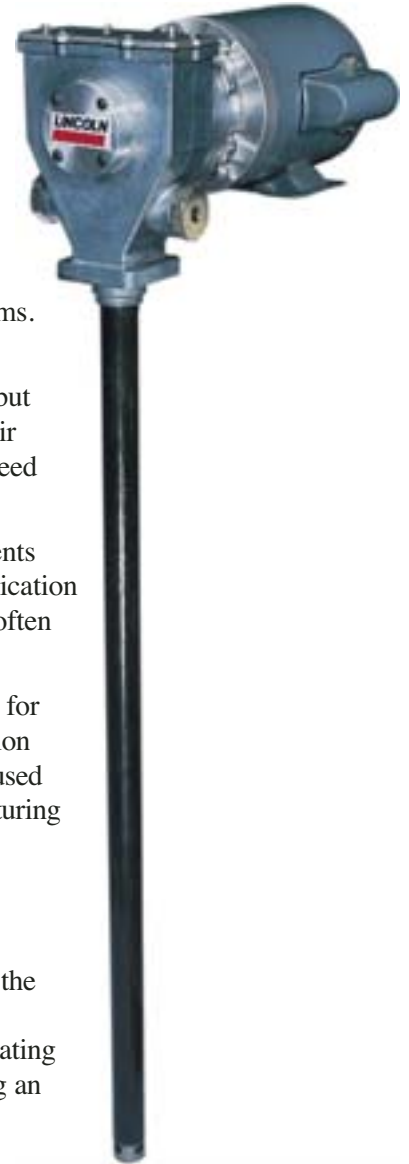

Features & Benefits

- ◆ Easy hookup because you just wire it in to your existing AC service
- ◆ Reduced installation cost because you don't need to pipe in compressed air or tap into hydraulic circuits
- ◆ Flexible output for different styles of lubrication systems is possible with available modular gear sets
- ◆ Built to last

Electric FlowMaster® Look Inside!

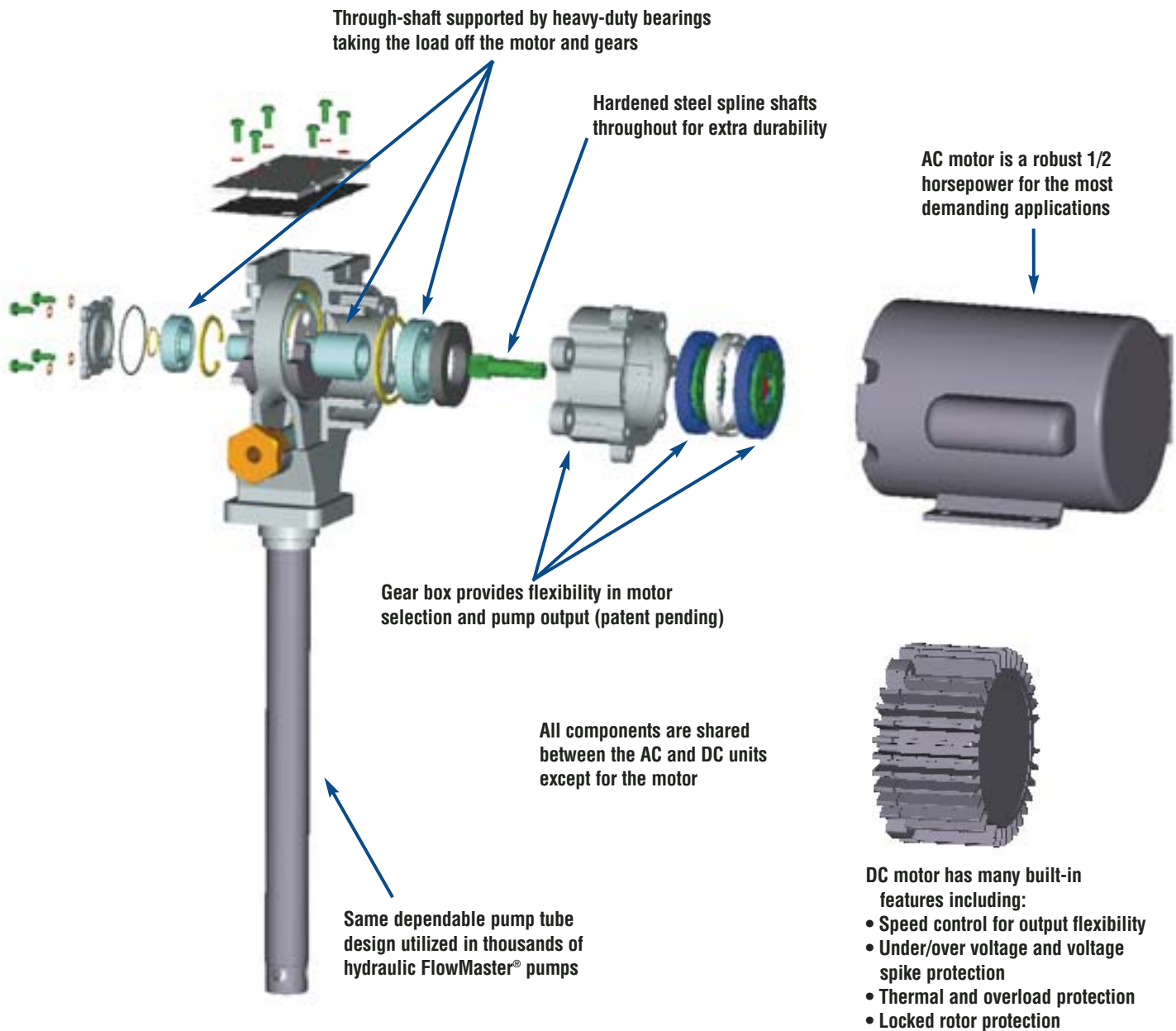

Technical Specifications for AC Models:

- 120/230 VAC
- 120-pound and 400-pound drum versions
- Output 24.5 in³/minute for #2 grease
- Maximum pressure: 5,000 psi
- Over-pressure protection integrated into design

24 VDC Electric FlowMaster® Pump

- **Enhanced for durability**
- **Electric Version of the Proven FlowMaster design**

Lincoln's new Electric FlowMaster Pump can serve many automated lubrication applications. Now you can take advantage of the ease and economy of this efficient, versatile electric pump—no cost for air associated with running the pump and no hydraulic hoses to connect.

The Electric FlowMaster Pump is a workhorse. It has an integrated speed control that allows you to adjust the pump's output to precisely fit any application. Lincoln offers six different models.

For manual lubrication, use the pump with a hose reel and a dispensing valve.

Applications

- Automated Lubrication Systems:
Mining/Construction Mobile Equipment,
Hammers/Breakers
- Manual Lubrication:
Via Hose Reel and a Dispensing Valve



Technical Specifications:

- 24 VDC
- 35-pound, 60-pound and 120-pound bare pump versions
- 60-pound and 90-pound and 120-pound canister assemblies
- Variable pump output from 2 to 20 in³/minute for #2 grease at 32°F and 1,000 psi back-pressure
- 35-pound pail version from 0.6 to 6 in³/minute
- Maximum pressure: 5,000 psi
- Over-pressure protection integrated into design

Features & Benefits

Product Description

This pump changes the rules of the lubrication game with its unique rotary drive and motor. Because of rotary drive and motor. Because of rotary drive, the motor can be placed directly on the pump. As a result, the pump is so compact it fits almost anywhere. It's versatile because its design lets users exactly adjust the pump output to fit their applications.

- ◆ **Supported/sealed shaft:** For added life
- ◆ **Planetary gear sets:** Improves efficiency
- ◆ **Brushless motor:** Ensures dependability
- ◆ **Thermal, overload, locked rotor, over/under-voltage protection:** Protects motor and increases the life of the pump
- ◆ **Built-in speed control:** Adjustable output for your specific application
- ◆ **Electric vent valve:** Proven reliable in tough environments
- ◆ **Return-to-tank relief valve:** Protects system from over-pressure and eliminates mess by returning lubricant to tank

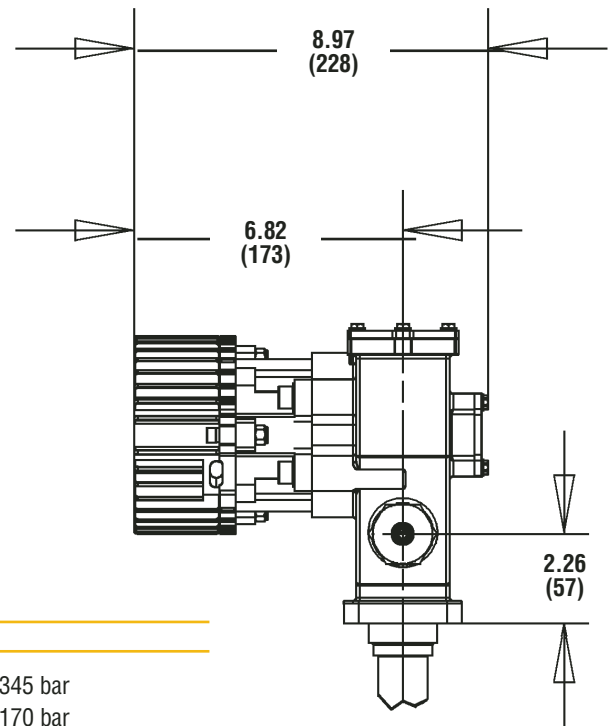
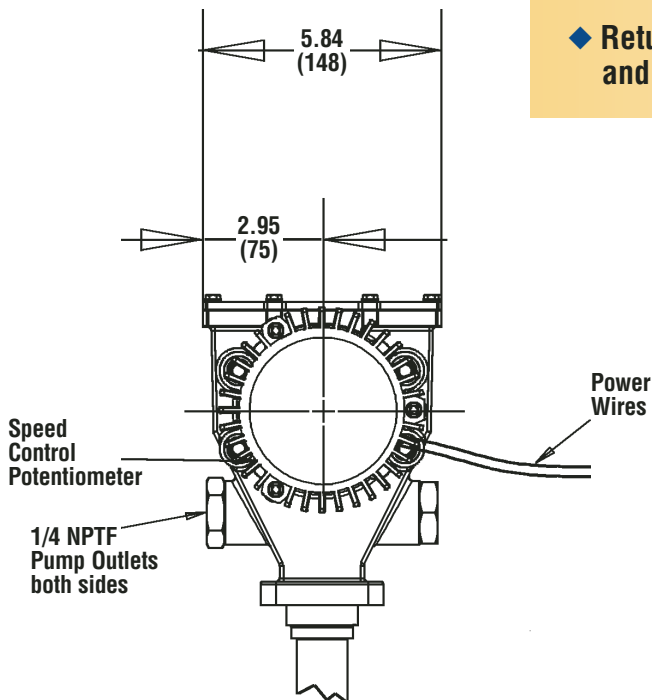

Specifications

Maximum outlet pressure	5000 psig	345 bar
85569	2500 psig	170 bar
Operating temperature range	-40° to +150°F	-40° to +65°C
Operating voltage	24 VDC	
Pump outlets	1/4" NPTF	
Motor	1/2 HP	
Current draw		
85568, 85567, 85471, 85472 and 85473	2-15 amps depending on backpressure	
85569	2-5 amps depending on backpressure	

85479 Hammer Package	
Complete with all components needed for installation including:	
Bare pump	85569
Drum cover	271705
Follower plate	252725

Available Models

Model No.	Pump/Bucket Size	Output	
		Min.	Max.
85569	35 lb (5 gal) pump	0.665 in ³	6.3 in ³
85567	60 lb pump	2.8 in ³	25.2 in ³
85568	120 lb pump	2.8 in ³	25.2 in ³
85471	60 lb bucket	2.8 in ³	25.2 in ³
85472	90 lb bucket	2.8 in ³	25.2 in ³
85473	120 lb bucket	2.8 in ³	25.2 in ³

Accessories

Description	35 lb	120 lb
Drum cover	271705	84616
Follower plate	252725	85492
Vent valve assembly		
24 VDC		85564
Strainer	272180	272180

FlowMaster[®] Hydraulic Pump

- **Versatile**
- **Modular design**
- **All-in-one package**

Lincoln's hydraulic FlowMaster pump changes the rules of the lubrication game. It's so compact, it fits almost anywhere. It's versatile because its unique rotary drive and control manifold let users adjust the pump to fit their applications exactly. It doesn't need electric power to run (it only requires an electric switch to start). And it doesn't need air, because the pump is designed to work off a hydraulic system. That means construction companies, mining operations and many other industries can confidently install the FlowMaster pump on trucks, excavators, loaders, draglines, conveyors, crushing machines, drills and many other applications.



Technical Specifications:

- **Major components:** control manifold, high-performance rotary motor, reciprocating pump tube, pump housing
- **Integrated manifold:** pressure gauge, flow control, pressure-reducing valve, on/off solenoid
- **Bucket features:**
 - Special coupling for easy maintenance
 - Enhanced low level
 - Stop-bolts on follower plate
 - 14-gauge steel wall
 - Large 3/4" NPT fill inlet

Our patented new technology offers you a variable flow rate up to 45 in³/min. Completely packaged with a modular design, FlowMaster Hydraulic easily pumps at low temperatures.

Features & Benefits

- ◆ **Patented technology**
- ◆ **Variable flow rate up to 45 in³/min**
- ◆ **Pumps at low temperatures**
- ◆ **Complete package—no additional components needed**
- ◆ **Modular design**
- ◆ **Compact size**

Accessories

Description	35 lb.	120 lb	400 lb.
Follower plate	252725	85492	270982
Drum cover	271705	84616	271606
Strainer	272180	272180	272180

Available Models

Model	Description
85487	60 lb. pump assembly for Centro-Matic
86258	60 lb. pump assembly with low level and follower plate for Centro-Matic
85585	90 lb. pump assembly with low level and follower plate for Centro-Matic
85220	120 lb. pump assembly with low level and follower plate for Centro-Matic
85482	Pump for 400 lb. drum (55 gallon)
85480	Pump for 120 lb. drum (18 gallon)
85481	Pump for 60 lb. canister (8 gallon)
85483	Pump for 35 lb. pail (5 gallon)

Ultrahigh-Pressure Pump Tube

Wire Line Protection for Oil and Gas Exploration

Our new ultrahigh-pressure pump tubes, models 85304 and 85305, are the solution to one of our customer's problems. Our customer's current equipment couldn't stand up to the increased pressures of tapping deeper reserves.

Oil and gas producers are drilling deeper, miles below the surface of the earth or ocean floor, to meet today's energy demands. Instruments deep in the well send data via pencil-sized cables to the surface. The cables pass through wire line flow tubes at the well head. The seal in the clearance between the cable and flow tube must hold against immense pressures, sometimes as much as 20,000 psig.

Our new wire line protection system pump makes the deep drilling and exploration possible. The pump, designed to withstand the intense pressure, maintains a "liquid o-ring" seal in the clearance between the cable and the wire line flow tube.

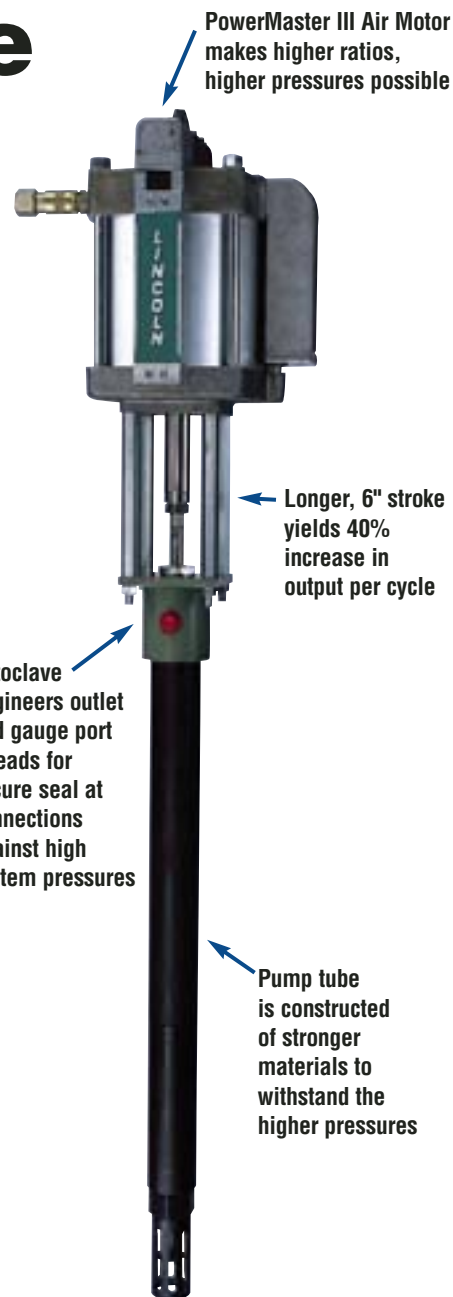

PowerMaster III Air Motor makes higher ratios, higher pressures possible

Longer, 6" stroke yields 40% increase in output per cycle

Autoclave engineers outlet and gauge port threads for secure seal at connections against high system pressures

Pump tube is constructed of stronger materials to withstand the higher pressures

Specifications

Pump Model	Ratio	Pump Tube	Air Motor	Max. Delivery Pressure psig (bar)	Max. Air Pressure	Pump Tube Length
2390	250:1	85304	84808	20,000 (1380)	80 (5.5)	33 ³ / ₄ " 85.70cm
2392	140:1		84806	14,000 (965)	100 (6.9)	
2394	70:1		85804	14,000 (965)	200 (13.8)	
2391	250:1	85305	84808	20,000 (1380)	80 (5.5)	27 ¹ / ₈ " 68.90cm
2393	140:1		84806	14,000 (965)	100 (6.9)	
2395	70:1		85804	14,000 (965)	200 (13.8)	

Max. Delivery Pressure psig (bar)	Average Output/Cycle	Output at 75 cycles/min	Operating Temperature Range	Wetted Parts Materials	Pump Stroke	Material Outlet	Gauge Port
20,000 (1380)	2 in ³ (33cc)	0.67 GPM (2.5 LPM)	-40°F to +180°F -40°C to +82°C	Carbon Steel, Brass, Polyurethane	6" (152mm)	Autoclave Engineers Medium Pressure Port for 9/16" Tube, 13/16 – 16 Thread	Autoclave Engineers Medium Pressure Port for 1/4" Tube, 7/16 – 20 Thread

Features & Benefits

- ◆ Strengthened tube design and PowerMaster III format adds 8-inch motor capability to the previous 6-inch limit to yield 20,000 psig (1360 bar) vs. 14,000 psig (952 bar) capacity
- ◆ Autoclave fittings—the industry standard
- ◆ Series III advantages: Modular air motor, 6-inch stroke

PileDriver® III Pumps

Technologically Advanced Pumps for Today's Demanding Applications

For more than 10 years, PileDriver III pumps have been recognized as the leader in diverse, demanding industries such as printing and publishing, automotive manufacturing and rotational molding. We've upgraded them for improved reliability, ease of use and longer life under the demands of increasingly tougher pumping applications.

One That's Right for You

Powered by Series III air motors, these reciprocating piston pumps come in two inlet styles and a wide range of ratios and output volumes to match each application's specific requirements. Choose from a wide range of accessories: Primers to handle the heaviest materials; Standpipes for tanks; Control valves, ejectors and measuring valves to meter and dispense materials; Air controls, hoses and hardware to complete the system.

Applications

Our pumps take on the toughest challenges from transferring lighter fluids (oils, solvents and adhesives) to moving medium-viscosity materials (RTV silicone, greases, coatings, plastisols and offset inks) to pumping very heavy viscosity materials (ink flushes, epoxies and mastics).

Product Description

PileDriver III pumps dispense materials from drums, stationary or tote tanks. They use the completely pneumatic, modular PowerMaster® III air motor and the optional AirBrake™ for runaway protection. The standard, patented gland protection bushing extends cycle life and service intervals. Standard polyurethane packings offer the best chemical and abrasion resistance for most applications. Other materials are available if compatibility is a problem. PileDriver III pump tubes are available with Hydro-PowerMaster hydraulic motors if air supply is a problem.

See Lincoln's Industrial Pumping Equipment catalog for the complete PileDriver III model line and specifications.



Technical Improvements:

- ▶ Bolted piston assembly for the PowerMaster 10" air motor replaces "pinned" design with a pre-stressed bolt for longer life, improved reliability; makes service of piston assembly easier and less expensive
- ▶ Improved air motor to pump tube rod connection for quieter operation over the pump's life
- ▶ Redesigned gland assembly enhances Lincoln's exclusive patented gland protection bushing which reduces leaks and increases seal life. All models now feature fixed gland instead of floating gland
- ▶ Optional ball valve for easier priming and orientation of the outlet used to draw samples
- ▶ New locking bolt design replaces set screws and makes the pump easier to adjust and secure in the desired outlet orientation

The Best Pump Just Got Better!

Lincoln PileDriver® Pump Tube

Upgrades make the pumps more reliable, easier to use and last longer

Look for more upgrades in the near future:

- Improved AirBrake™
 - Easier to adjust
 - More positive control
 Q1-2004
- 4"-Dual Inlet Standpipe
 - Less resistance on suction side for better flow with high-viscosity materials
 Q4-2003
- 4 Wheel Caster Base
 - Pump is easier to position, tote is easier to change
 Q4-2003

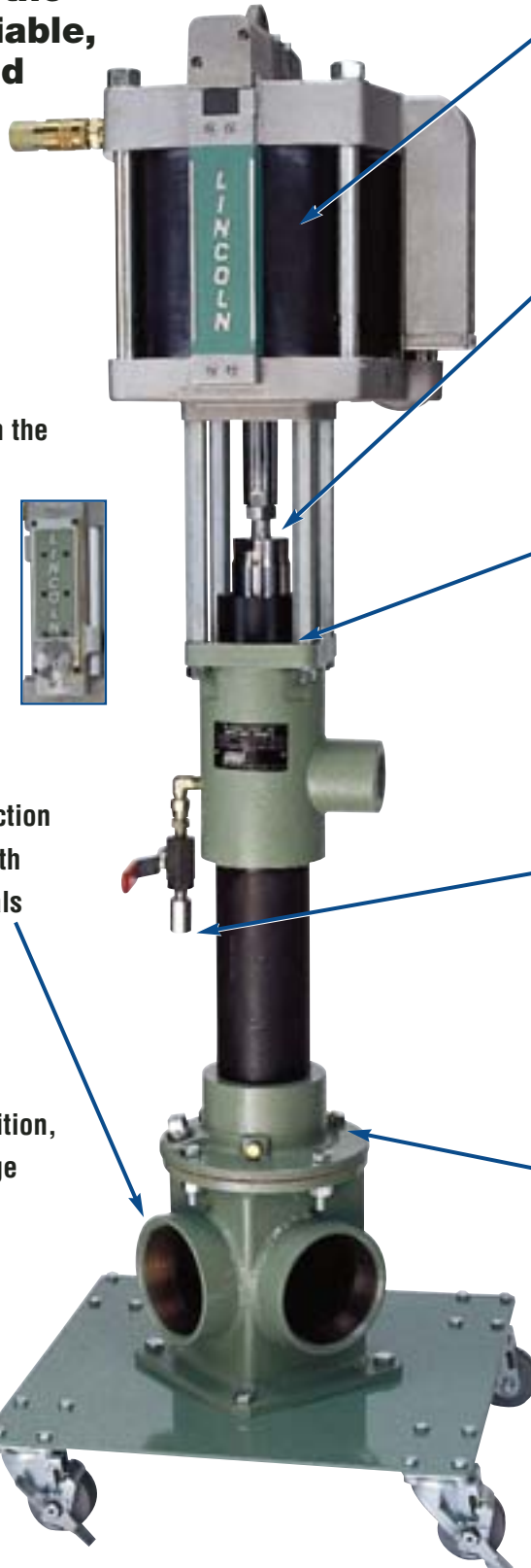

Bolted piston on 10" air motor—increased durability and easier to service



Stronger air motor to pump tube connection—for quieter operation over the life of the pump



Redesigned gland assembly enhances Lincoln's exclusive patented gland protection bushing to reduce leaks and increase seal life. All models now feature fixed gland instead of floating gland.



Optional ball valve (model 85612) for easier priming and orientation of the outlet for drawing samples

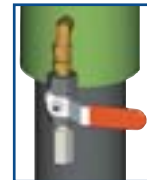

New locking bolt design replaces set screws and makes the pump easier to adjust and secure in the desired outlet orientation



PileDriver® III Pumps

Series III Air Motor Features

Features & Benefits

- ◆ These fully pneumatic air motors reverse stroke direction without mechanical linkages and are simpler and more reliable than older designs
- ◆ Air motors are 3-4-6-8-10 inches (76-101-152-203-254 mm) diameter
- ◆ Modular construction: Air motors are easy to install and maintain
- ◆ Built-in muffler: Meets or exceeds OSHA requirements at recommended air pressures
- ◆ AirBrake® options: Stops runaway pump, prevents product spills, damage and excess wear and activates an optional remote alarm device
- ◆ AirBrake available already installed (refer to pump specification charts) or can be ordered separately as Model 84988. For remote monitoring of AirBrake, order model 244398 signal kit



PileDriver Series III Pump Tube Features

Features & Benefits

- ◆ Machined inlet casting: Hex head screws secure the inlet assembly and permit 360° outlet adjustment to facilitate system plumbing and provide for easy pump removal/replacement
- ◆ Cartridge-type gland with scrapers and patented protection bushing: Extends the life of gland packings by protecting them from excessive material buildup and pressure fluctuations. Cartridge removes easily for routine service
- ◆ Straight through pump tube and piston port design: Reduces internal friction and the opportunity for solids entrapment
- ◆ Load bearing, chrome-plated internal pump tube surface: Distributes forces between gland and pump tube to prolong seal life
- ◆ Choice of inlets: Shovel type for thick material or flat check for higher flow rates

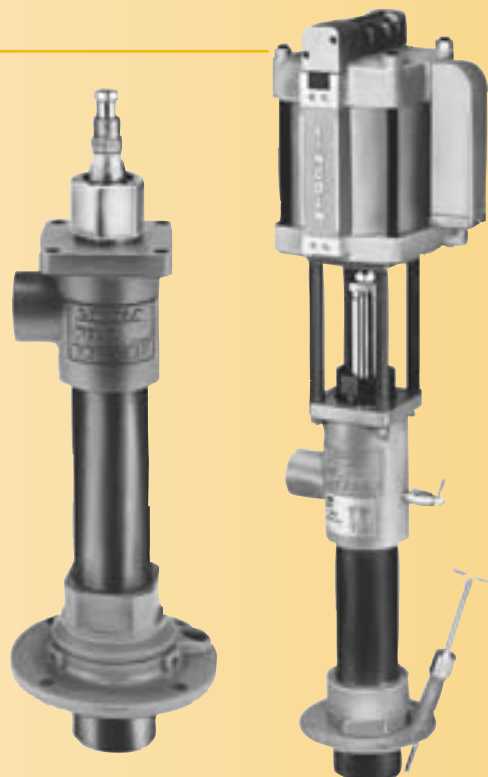

Model 1735

Redesign and Upgrade

Model 1735, our popular 3-inch, twin-post pressure primer, has been improved for better performance. The nickel-plated, fabricated carbon steel follower and one-piece twin blade wiper replace the aluminum follower and dual O-rings and provide positive sealing against high-viscosity fluids.

- Model 1735 for PileDriver® III Pumps and 55 gallon drums
- Model 1736 for PowerMaster® III Pumps and 55 gallon drums

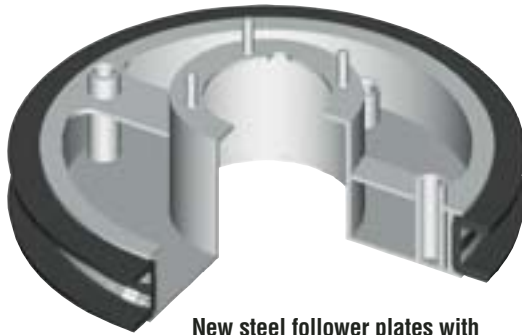

New steel follower plates with twin blade wiper for positive seal against drum and chimes

New twin blade wiper seals



Specifications

Recommended Viscosity Range	Air Cylinders	Maximum Air Pressure	Priming Pressure @ 100 psi (7 bar)
200K to 500K Centipoise	Two 3" (7.62 cm)	150 psi (10.2 bar)	3 psi (0.2 bar)

Features & Benefits

- ◆ **Positive-priming force on the material:** Downward force of the follower forces material into the pump inlet, assuring positive priming of high-viscosity materials
- ◆ **Follower has an Elastomer seal:** Twin blade wiper seals against the material container's sides, preventing drying and contamination of the material and wipes the container's sides clean
- ◆ **Four-way air valve control:** This directional valve controls up/down movement of the follower. Primer unit remains coupled to the air system at all times (use of an air regulator and gauge is recommended)

Note: For a full range of pressure primers, please see the Lincoln Industrial Pumping catalog.

Thermal Pressure Relief Device

Managers of vehicle service centers can now turn to our new thermal pressure relief device to protect against possible damage to their closed pipe systems caused by thermal expansion. For example, as oil warms, it expands and causes pressure—sometimes oil that was 300 psi becomes 2,000 to 3,000 psi. Such pressure spikes can cause costly damage if they exceed the design capacity of pipes and system components.

Our pressure relief valve returns fluid/material back to the tank, limiting the pressure to protect the system prevent leaks.

Applications

Air-operated piston and diaphragm pump systems that are normally stalled and subject to fluid temperature differentials.

- Model 282876 is typically used with piston pumps
- Model 282902 is typically used with diaphragm pumps

Specifications

Model No.	Pre Set Relief Pressure	Port Size
282876	1000 psi (6.8 bar)	1/2" NPT Female
282902	150 psi (10.2 bar)	

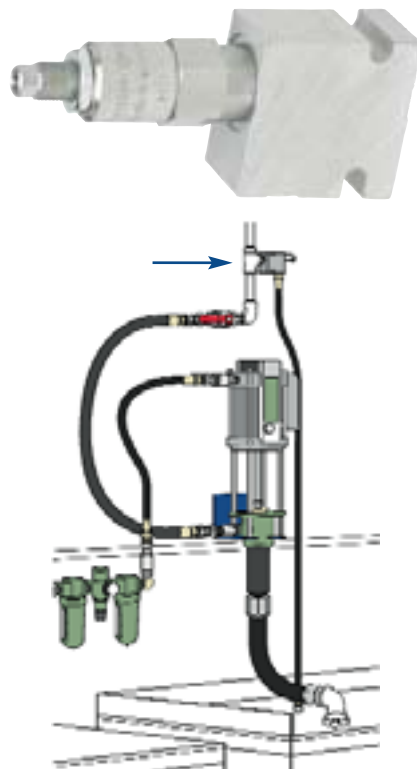

Your System, from Design through Maintenance

Lincoln's worldwide network of full-service distributors can design a system that's right for you. They know how to correctly match the system components to your applications and conditions. Their knowledgeable technicians can also install the system or work with your personnel to make sure the job is done correctly. After installation, you can count on these professionals to help you choose the maintenance option that ensures your system's optimum function, safety and long service life.

Each distributor stocks a full inventory of pumps, metering devices, controllers, monitors and accessories. Each continues to meet our stringent requirements for product, systems and service knowledge.

SOLUTIONS

contains new product information for Lincoln customers.

Please direct ideas, comments or questions to:

Lincoln Marketing Communications,

Tel: 1-314-679-4255 or 4401, Fax: 1-314-679-4359

www.lincolnindustrial.com.



Lincoln Industrial Corp.
One Lincoln Way
St. Louis, MO 63120-1578

Phone 314-679-4200
Fax 314-679-4359
www.lincolnindustrial.com

Form 442967 (8/03)
© Copyright 2003
Printed in U.S.A.