

Centralized Lubrication for the Food & Beverage Industry

Experience Productivity



Insufficient lubrication brings machines and lines to a screeching halt. Proper lubrication saves valuable time and makes maintenance routines simple.

Quicklub Progressive System

Ideal for Individual Machines

Economical & Reliable

Quicklub Systems have been designed to meet the toughest requirements of the food & beverage industry. Their operation is based on the reliable progressive principle in which the lubricant is dispensed by a piston pump via progressive plunger metering devices to the lubrication point. The lubrication occurs in metered, timed intervals at a maximum pressure of 350 bar. Thus the lubrication of bearings with high back-pressures is also guaranteed. The pump can serve up to three independent circuits, each with its own pump element, consisting of numerous lubrication points with lubricant.

The system is easy to monitor and ensures that the right quantity of grease is supplied to the lubrication points.

Quicklub® System Benefits

- No corrosion of the light-weight pump housing which is made of heavy-duty, fiber-reinforced resin.
- The pump motor is protected against damage and moisture.
- 2, 4, and 8-liter reservoir (Optional with filling from the top and a lockable lid). A special 2 liter flat version is perfect for very low installation areas because it's only 244 mm high!
- 4 different pump elements with fixed or variable output

- Over-pressure valve – also equipped with an indicator and reservoir return
- PLC controllable or fully-automatic via integrated circuit board
- Installation can be performed with threaded or Quicklinc™ plug-in type fittings.
- The high-precision progressive metering device in block-form allows pressure differences of 100 bar and eliminates leaks.



- Multiple outlets of the progressive metering device can easily be internally combined without the need of external connectors.
- Progressive metering device also available in stainless steel

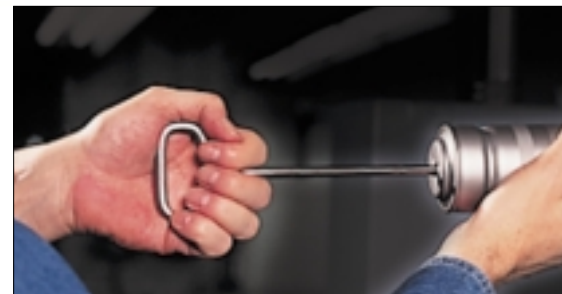

Filling of Quicklub Pumps: Fast and Easy

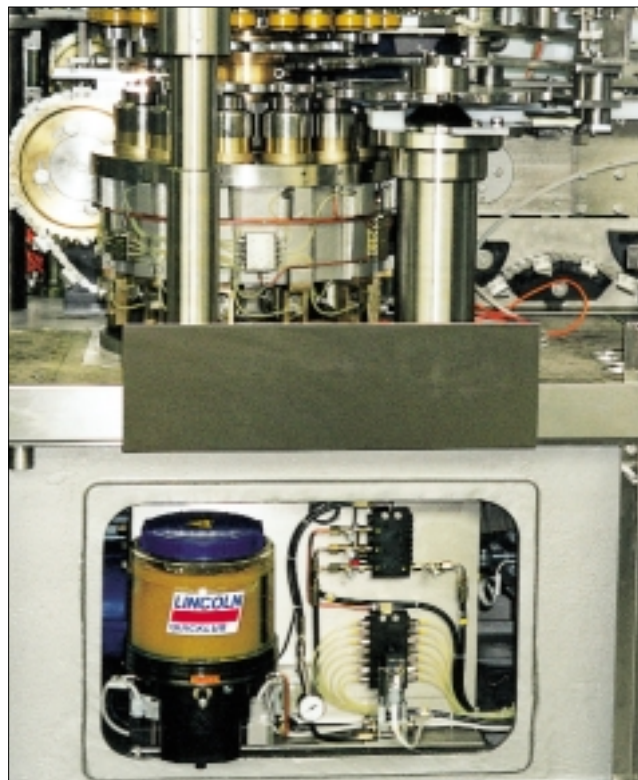

Filler with a Quicklub Progressive System

QLS 301 Power Package

The Solution for the Supply of Few Points

Three in One – Compact, Sturdy, Multi-tasking

The QLS 301 is a complete system. It comes pre-assembled with everything a system needs: all kit components and a built-in over-pressure valve. No system assembly is necessary as is usually required with common lubrication systems. Lubrication points can be supplied with NLGI 2 grease (QLS 301) or oil (QLS 311) directly from the pump at an affordable price. The long list of standard features is a remarkable characteristic of the QLS pump.



QLS has all the components and all the functions needed to lubricate at a professional level. The compact design makes it easy to find an installation location even in the most unthinkable places.

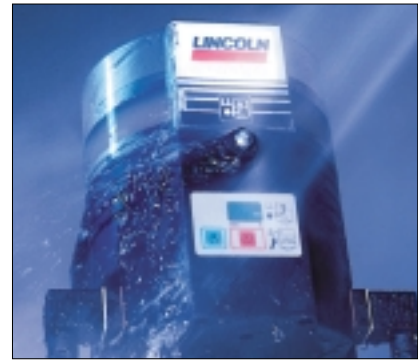

erating times, monitors the function to ensure lubricant is fed, and allows additional lubrication cycles to be initiated. Settings are always at your fingertips – all settings are performed with ease via keypad. Settings and messages are shown on the built-in display window.

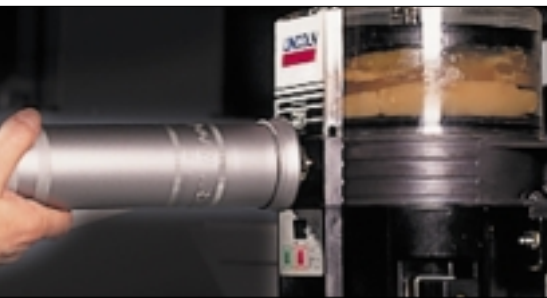

Ideal for:

- Machines with few lubrication points
- Chain lubrication
- Isolated lubrication points

It's compact

The QLS is not only a pump. It contains a control and monitoring unit and a divider block as well.

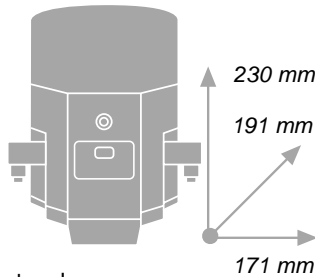

It's sturdy

The QLS may be small, but its performance is powerful. It can handle temperatures ranging from -25°C to +70°C, variable mounting positions and high pressure washdowns (IP6K9K, NEMA 4 protection).

It's Multi-tasking

The QLS features multi-tasking. An integrated circuit board optimally controls pause and op-

Standard Features:

- Complete, compact system ready to use "out of the box"
- Variable mounting position
- Integrated circuit board with system function monitoring
- Integrated display and keypad
- Standard low-level control
- Built-in over-pressure valve
- Internal lubricant return possibility
- Available with or without attached divider block (up to 18 outlets)
- Optional external fault contact



Palletrierer mit einem QLS System



Dependable Centralized Lubrication S

The Answer for Production Lines

Lincoln lubrication systems are designed to keep your production line running, and to match your needs. Our systems help reduce your maintenance work. Depending on the application, systems such as two-line, single-line or sectional systems are all part of the Lincoln range.



Container Supply System

Experience Productivity:

- Lincoln complete system guarantee
- Decades of experience in serving our customers
- Ensures process safety
- Quick Payback
- Self-manufactured pumps and metering units
- Choice of reservoir, drum or container type pumps
- PLC controllers with ASI-Bus (Actuator Sensor Interface) that minimizes wiring and ensures maximum efficiency

The Classic Helios Two-line System

Two-line systems are used to supply lubricant to lubrication points of entire filling and packaging lines. One centrally located pump is capable of reliably supplying over 2000 points with lubricant.

A higher flexibility in the metering of lubricant is achieved in combination with Quickclub progressive divider valves. Also the cost effectiveness speaks for a combined system. Helios two-line systems may be extended at any time.

Features

- Perfect for widely dispersed lubrication points
- Visual or electrical monitoring of each outlet pair
- If one bearing should block-up, all other outlet pairs continue to supply lubricant
- Simple and individual metering of the lubricant – each outlet pair can be adjusted separately
- Divider valve also available in stainless steel
- Intelligent control which automatically adjusts the minimum required system pressure – thereby increasing life-span of components



Conveyor with two-line and progressive metering devices

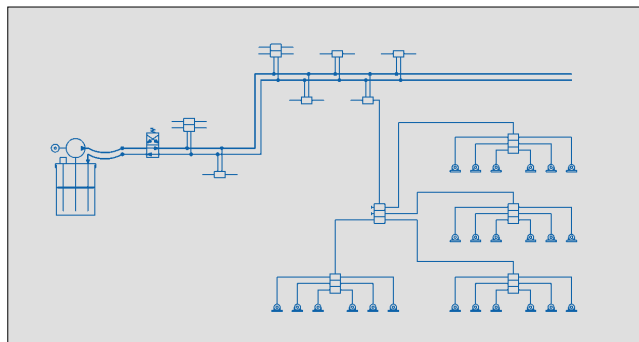

Systems: Turnkey

The Revolutionary Ejector Sectional System

The ejector sectional system is ideal for production lines, in which sections or zones are operated separately. Here, sections may be controlled independently and monitored individually. The ejectors, which may be classified as a compact pneumatic metering pump, are supplied with lubricant from one single feed line. The ejectors are controlled on demand and supply an exactly metered lubricant quantity to the downstream progressive divider valves.



Ejector cabinet with ASI-Bus

Features

- Ideal for the centralized lubricant supply for sections that run separately.
- Zones are controlled separately – individual pause times and operating times
- Electrical monitoring of each lubrication cycle and of all connected lubrication points
- Low system pressure in the main line
- Adjustable system pressure for each section
- Variable lubricant output



Section of a filling line with ejector cabinet

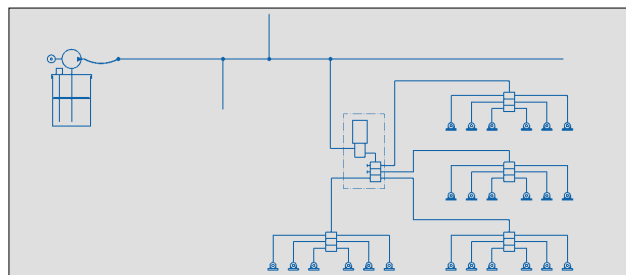

The Flexible CentroMatic Single-Line System

CentroMatic single-line systems are used when the quantity of lubricant per point largely differs. The flexible, and direct operating CentroMatic injector has a metal-to-metal fit and a spring-loaded metering pistons that can supply lubricant at high pressures (up to 240 bar for grease and 68 bar for oil). Thus, oil and grease up to NLGI class 2 may be used.

Each independently operated injector serves only one lubrication point and may be accurately adjusted to deliver the precise amount of lubricant required. Provided the pump capacity is sufficient and the tube dimensions are appropriate, the system may be enlarged at any time.

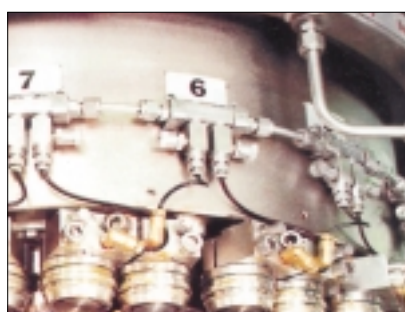

Machine with injectors

Features

- Individual metering per lubrication point
- Visual monitoring
- Simplicity – easy to understand and install
- Extra lubrication points may easily be added
- Injectors also available in stainless steel
- Special injector versions for high temperature

EVD-FL Injectors for oil

The new generation of oil injectors are available in an aluminum or synthetic fiber version that provides all advantages of the typical CentroMatic system plus corrosion-proof, light-weight and maintenance-friendly characteristics. Flanged mounting plates simplify servicing, as tube fittings no longer need to be loosened in order to service the injector.

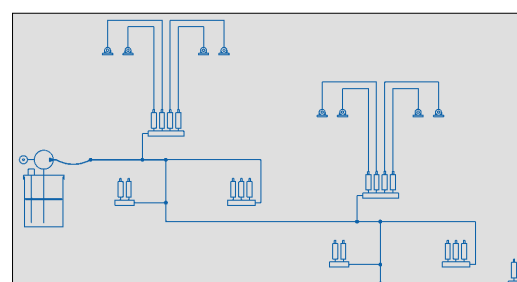

The Precise Chain Lubrication System

Clean – Safe – Economical

Chains play an important roll in automated production. Independent of their application, chains have friction points that are the “weakest link”. The proper lubrication of these points minimizes corrosion, flushes out contamination, reduces chain elongation and minimizes energy consumption.

In the food & beverage industry a chain must satisfy high demands and prove its reliability day in and day out, often under extreme



conditions in a cold-storage or in a baking oven.

The Lincoln-ORSCO precise spray system delivers an ultra-fine, non-mist amount of lubricant exactly where it is needed. Only the required amount of lubricant for a proper coverage is applied, resulting in significant cost savings by decreasing the lubricant consumption and minimizing cleaning costs

Features

- Reduction of lubricant usage by up to 90% drastically shrinks cleanup costs.
- Capable of dispensing one drop (0,03 ml) of lubricant continuously for a period exceeding four minutes.
- Lubricant is precisely applied to only the points where it is required.
- No change in spray pattern, even when another drop of lubricant is injected.
- Capable of lubricating chains with low speeds to those with speeds in excess of 300 m/min.
- Increase chain life
- Reduces product contamination
- Reduction in chain elongation
- Lower chain motor amperage, saving power

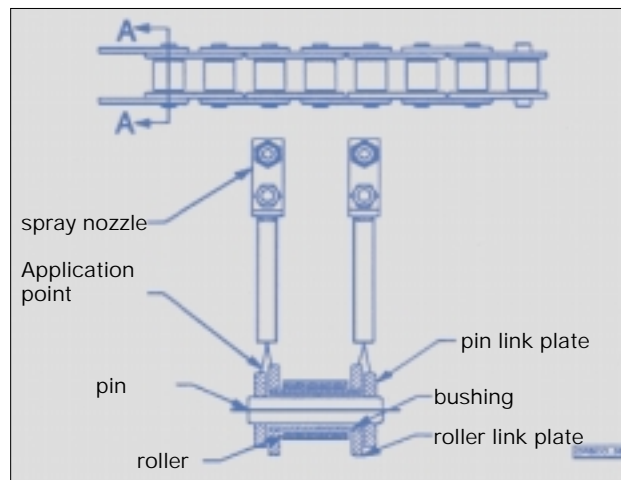

The spray patterns beside show 1/2 drop of lubricant dispensed over 1 second, 10 seconds and 20 seconds.

Lincoln's Complete Service

Safety and Optimum Productivity

Our job is only done when our customer is satisfied and remains so.

Lincoln provides a special performance and service offer geared to all needs of the food & beverage industry. We see ourselves as your competent partner for the engineering, the assembly, the commissioning and, the maintenance of your individualized turnkey centralized lubrication system. Our customers can rely on maximum safety and service when operating their systems. For our extensive service, our highly qualified personnel is at your disposal.



Lincoln's Complete Service Modules

- Engineering and consulting
- Telephone support
- Assembly and commissioning
- Training
- Maintenance programs
- Financing

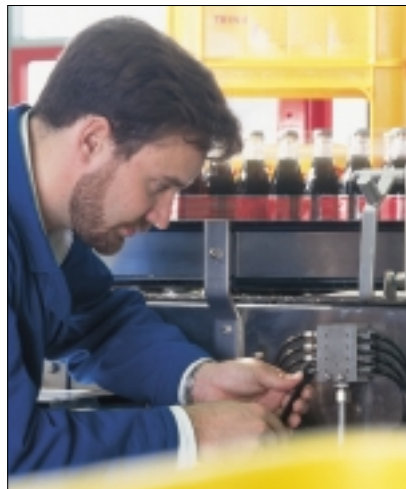

Even the best technical components only provide optimum performance if assembly and repairs are carried out by qualified and specialized personnel. For this reason, Lincoln service provides improved safety, increased up-time and optimum productivity for lubrication systems.

Your Advantages

- Warranty for the complete system
- Possible warranty extension
- Installation according to legal regulations
- Safe operation of the lubrication system
- Efficient and smooth running system
- Increased economies of scale

As your successful and competent provider of centralized lubrication systems, we are represented for you and your customers in more than 90 countries worldwide.

Contact Lincoln for your lubrication requirements
Top in know-how, technology and service.

Automated Lubrication

The Path to Cost Reduction

A lack of lubrication can bring your machines and production lines to a screeching halt. The increased cost of lubricants and maintenance duties, coupled with a higher machine value, drives the need for automatic, centralized lubrication systems.

Harsh conditions such as water, soap and mechanical loads cumulatively result in a high wear rate of bearings and friction points.

Lubrication is therefore absolutely necessary in order to provide the right protection. Lincoln lubrication systems are a reliable means of regular lubrication.

While the machine is in operation, the lubricant is automatically delivered in time-controlled and metered quantities to all connected points in the system. Lubrication "in motion" ensures that the lubricant is optimally and evenly distributed within the bearing, thus reducing friction and premature wear. This is the ultimate form of lubrication applied in a systematic manner.



Increased safety is another important factor. Dangerously located or hard to reach lubrication points no longer need to be accessed by hand. What's more, is a reduction in maintenance costs by the elimination of time consuming, tedious tasks and a reduction in lubricant consumption.

Large Savings = Fast Payback

The installation of a centralized lubrication system drastically reduces repair and maintenance costs. In addition lubricant consumption is cut and the life span of wear components is increased. This automatically reduces downtime and operation costs.

Automated vs. manual lubrication

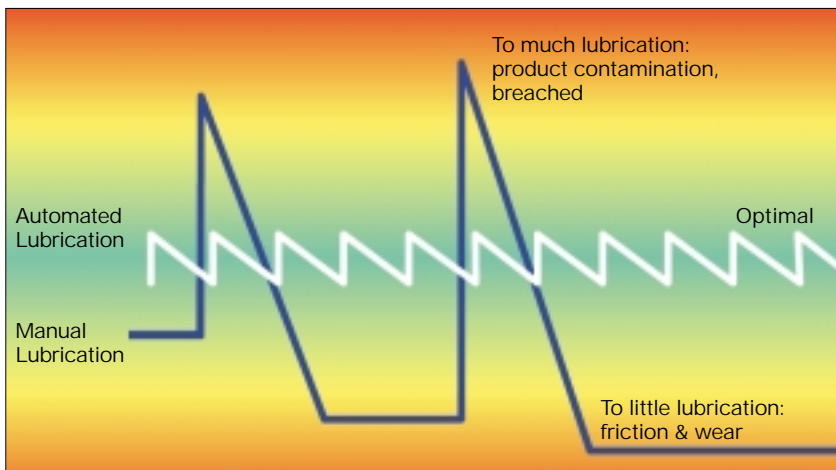

- Increased profits and productivity
- Lower costs for repairs, spare parts and lubricant
- Improved operating times; less costly downtime
- Longer maintenance intervals
- Dramatic reduction in lubrication-related bearing failures
- Significant contributions to safety and the environment