



TECHNICAL SERVICE BULLETIN

Bulletin Number: DC-2277

Date: 6/1/2010

**Affected Model(s): Lincoln Fluid System Components-Pumps, Reels,
Meters, Dispense Valves, Hoses, Fittings**

Subject: Pressure Relief Kits

Recently we released five new Lincoln Pressure Relief Kits that provide over-pressurization protection due to thermal expansion in a fluid delivery system. They are simple kits that include a pressure valve installed at the pump outlet with necessary fittings, a bung, or other type of adapter, and a fluid return line (back to suction tube through the bung).

[Sales Bulletin DC-2276](#) (use link to review) was recently released and gives in depth details regarding everything you should know about the effects of thermal expansion and why it should be controlled. It also describes how thermal expansion can damage a system, what conditions may exist with an over pressurized system, and complete details of what Lincoln offers to protect against thermal expansion.

Also attached is an owner's manual and service page regarding our new pressure relief kits (Section K5, Page 31). Details are provided regarding the specific kit for a given Lincoln pump, and typical installation instructions for the pressure relief kit chosen. The new pressure relief kits will ultimately be required on all Lincoln fluid supply systems. Failure to specify these protective devices can and will void the warranty of the specific products in the system. Please keep in mind that the effects of spikes in system pressure are not isolated to the pump only. Other specific items could be: hoses that burst for no apparent reason, reel swivels that leak, inlet swivels on meters or dispense valves that leak, non-drip nozzles on dispense valves that drip, miscellaneous installation fittings that drip, and others may be a direct result of increased pressure due to thermal expansion.

We intend to be fair when it comes to requiring use of these pressure devices in lube systems since we are just introducing them. With this being true we are "grandfathering in" existing installations. It would be highly recommended to add protection if ongoing issues persist. Installations made, or quotations submitted prior to 6/1/2010 will not require thermal relief to claim warranty. All such installations and quotations will receive

recommendations from Lincoln to include thermal relief valves as part of warranty repair process. Installations made, or quotations for fluid systems made from 6/1/210-9/1/2010 should include thermal relief, but will not be required for warranty consideration. After 9/1/2010 all warranty claims that are deemed to be a direct result of the effects of thermal expansion and no thermal devices were provided by the installer will be denied.

As always, if you have questions or concerns, please do not hesitate to call Lincoln Technical Services at 314/679-4200, Ext. 4782 or fax us at 314/679-HELP (4357).

Regards,

Barry Frankum

DESCRIPTION

Pressure relief kits provide over-pressure protection from thermal expansion of fluid in a system. The pressure relief kit mainly consists of pressure relief valve installed at pump outlet with fluid return line and fittings.

OVER-PRESSURE PROTECTION PLANNING

The protection planning involves the following: pressure relief valve pressure setting, valve location and routing. It is imperative that the pressure ratings of components in the system be higher than the pressure setting of relief valve.

Pressure relief valve should be installed close the pump outlet to gain routing efficiency and proper protection. The pressure relief kits listed here are based on Lincoln oil pumps. No check valve should exist after the pressure relief valve.

PRESSURE RELIEF KITS

Five pressure relief kits are listed in this service manual. Two are for PMV pumps with different pressure settings: 900 psi and 1500 psi. One kit is for Series 40 oil pump with pressure setting of 900 psi and a different pump tube adaptor. Two kits are configured for diaphragm pumps with different outlet thread size: 1/2" or 1" NPTF. These two kits have the same 150 psi pressure setting.

Table 1 shows these five pressure relief kits with applicable pumps and outlet thread size.

Table 1 - Pressure Relief Kits

Kit Model Number	Applicable Pumps	Outlet Thread Size	Pressure Setting (psi)
277601-1	V305000000, V406000000	1/2"	900
277601-2	V410000000	1/2"	1500
277601-3	84933	1/2"	900
277601-4	85622, 85623, 85624, 85626, 85631, 85632, 85633	1/2"	150
277601-5	65628, 85627, 85629	1"	150

! CAUTION

No ball check should be used in the pump extension suction tube when pressure relief kit is installed with adaptor 277602 or 277603

TYPICAL ASSEMBLIES OF PRESSURE RELIEF KITS

1. Pressure Relief Kits Assembled With Bung Adaptor

Figure 1 shows the exploded view of a pressure relief kit with bung adaptor for PMV pumps. Table 2 lists parts in two pressure relief kits and applicable PMV pump models.

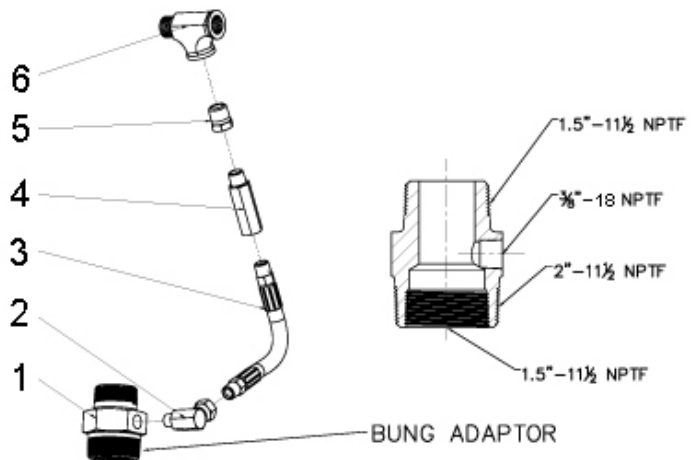

Figure 1

Table 2 Pressure Relief Kits for PMV Pumps

KIT MODEL NUMBER	277601-1		277601-2
	PUMP RATIO	5:1	6:1
AND PUMP MODELS	V305000000	V406000000	V410000000
Item	Description	Part Number and Description	
1	BUNG ADAPTOR	277602 - Pump Tube to Bung	
2	90° UNION SWIVEL	247590 - 3/8"-18 NPTF (m) x 3/8"-18 NPSM(f)	
3	HOSE	277605 - 3/8"-18 NPTF (MBE) x 12" Long	
4	RELIEF VALVE	277604-1 (900psi)	277604-2 (1500psi)
5	REDUCER BUSING	67069 - 1/2" (m) x 3/8" (f) NPTF	
6	TEE	273083 - 1/2" (f) x 1/2" (m) x 1/2" (f) NPTF	

! WARNING

Prior to installation, release all pressure in the system.

- Disconnect the air supply line to the air motor.
- Make sure the manual is read thoroughly and properly understood.

MODEL 277601-1, -2, -3, -4, -5 Pressure Relief Kits



The orientation of pump outlet, tee branch and union swivel should be taken into consideration to accommodate the pump tube length versus the length of hose. Figure 2 shows some possible installation configurations.

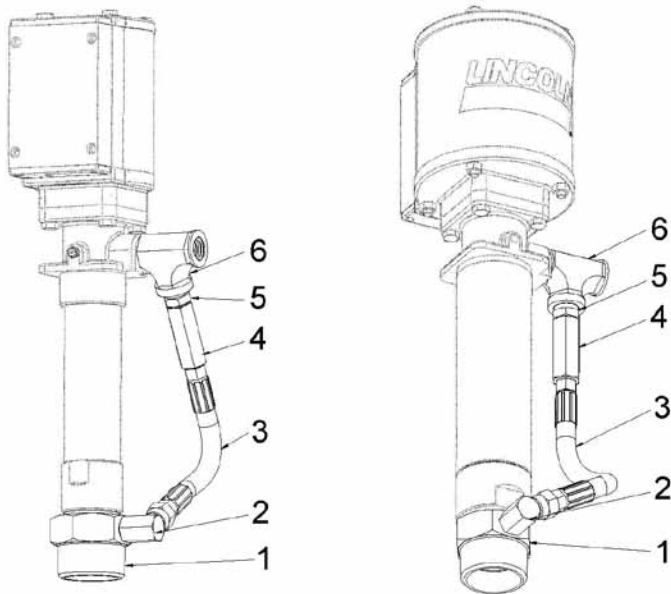

Figure 2 Possible Pressure Relief Kit Installation Orientations

2. Pressure Relief Valve Directly Connecting To Oil Tank or Reservoir

Pressure relief kit could also be installed without using any adaptor connecting to the pump foot valve. Figure 3 shows that Lincoln PMV and Series 40 pumps with such pressure relief valve directly connecting to the drum oil tank or reservoir.

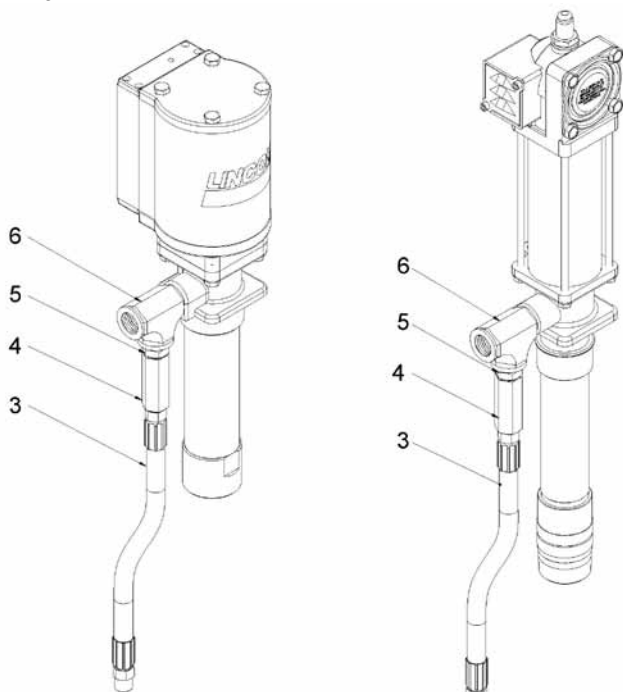

Figure 3 Pressure Relief Valve Direct to Oil Tank

3. Pressure Relief Kit With Lincoln Series 40 Oil Pump

The adaptor PN277603 shown as item 1 was designed for Lincoln Series 40 oil pump. The lower end of the adaptor has the same thread arrangement as that of the foot valve body of oil pump. Figure 4 shows a pressure relief kit with a Series 40 oil pump. The part list of Kit 277601-3 is shown in Table 3.

Table 3 - Parts List of Kit 277601-3

ITEM NO.	PART NUMBER	DESCRIPTION
1	277603	ADAPTOR, FOOT BODY TO TUBE
2	247590	90° UNION SWIVEL, 3/8"-18 NPTF (m) x 3/8"-18 NPSM(f)
3	277605	HOSE, 3/8"-18 NPTF (MBE) x 12" Long
4	277604-1	PRESSURE RELIEF VALVE, 900 PSI
5	67069	REDUCER BUSHING, 1/2" (m) x 3/8" (f) NPTF
6	273086	TEE, 1/2" (f) x 1/2" (f) x 1/2" (f) NPTF
7	242749	PIPE NIPPLE, 1/2" NPTF x 4"L

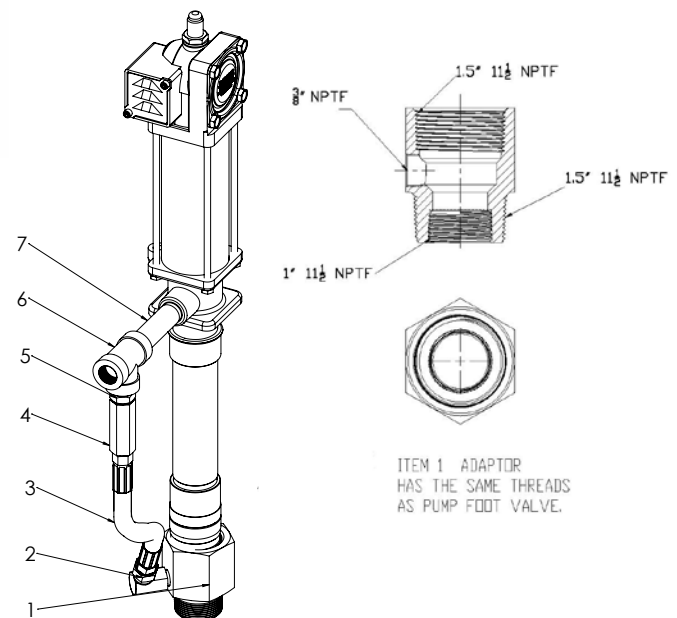

Figure 4 Pressure Relief Kit For Series 40 Pump

4. Pressure Relief Kit With Diaphragm Pumps

Two pressure relief kits are configured to fit two sizes of diaphragm pumps: one is for pump of 1/2" outlet, the other is for a 1" outlet. Figure 5 shows kit 277601-4 with the outlet and inlet of diaphragm pump at one side. The picture is for reference only.

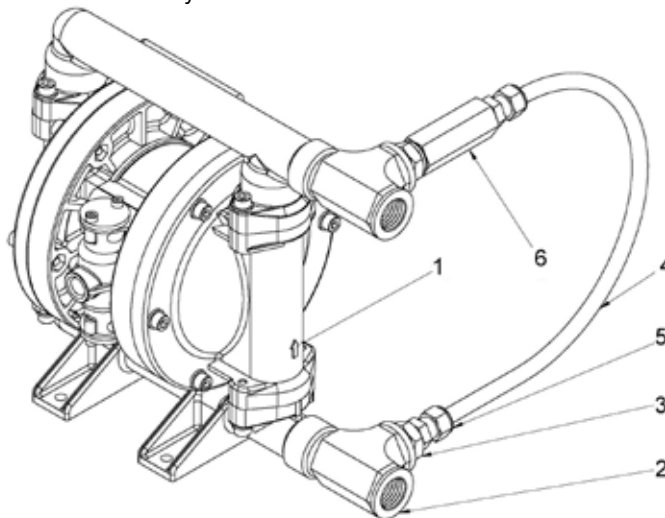

Figure 5. Pressure Relief Kit for 1/2" Air Operated Diaphragm pump

Table 4 - Parts List of Kit 277601-4

ITEM NO.	PART NUMBER	DESCRIPTION	QTY.
1	REFERENCE ONLY	DIAPHRAGM PUMP, 1/2" NPTF OUTLET	1
2	273083	PIPE TEE, 1/2" NPTF MALE RUN	2
3	67069	REDUCER BUSHING, 1/2" MPT TO 3/8" FPT	2
4	277607	NYLON TUBING, 3/8" OD	1
5	277608	CONNECTOR-3/8" Tube x 3/8" NPT	2
6	277604-0	PRESSURE RELIEF VALVE, 150 PSI	1

Figure 6 shows kit 277601-5 with Lincoln diaphragm pump 85628 as reference.

Note: It is possible that the outlet TEE might be in the vertical position. In such case, the TEE branch at fluid inlet should be in horizontal position and pointing to the same direction of branch of outlet TEE. Figure 7 shows such arrangement.

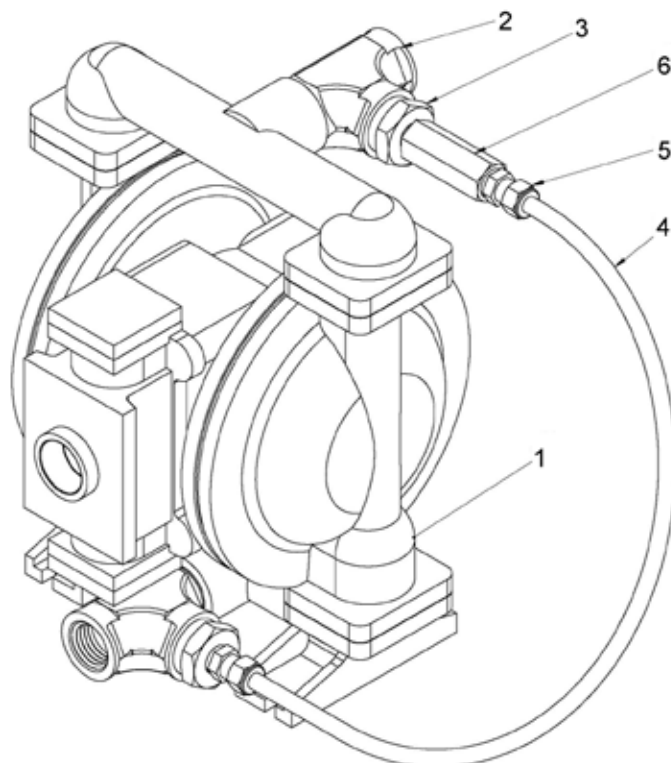

Figure 6 Pressure Relief Kit for 1" Air Operated Diaphragm Pump

Table 5 - Part List of Kit 277601-5

ITEM NO.	PART NUMBER	DESCRIPTION	QTY.
1	85628 AS EXAMPLE	DIAPHRAGM PUMP, 1" NPTF OUTLET	1
2	277606	PIPE TEE, 1" NPTF MALE RUN	2
3	276861	REDUCER BUSHING, 1" MPT TO 3/8" FPT	2
4	277607	NYLON TUBING, 3/8" OD	1
5	277608	CONNECTOR-3/8" Tube x 3/8" NPT	2
6	277604-0	PRESSURE RELIEF VALVE, 150 PSI	1

MODEL 277601-1, -2, -3, -4, -5 Pressure Relief Kits

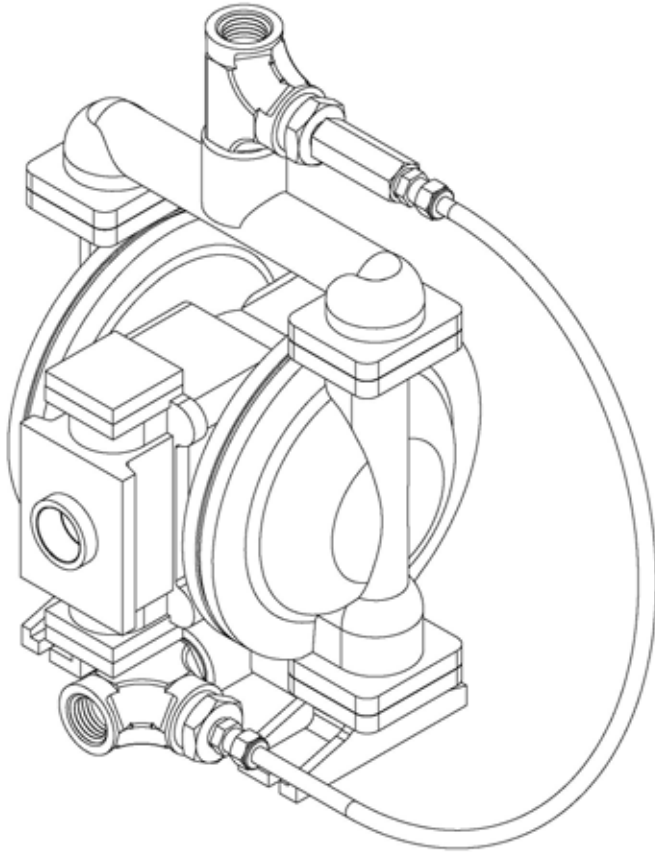

Figure 7 Pressure Relief Kit Arrangements with Upward Outlet

PRESSURE RELIEF KIT INSTALLATION

Installation Procedures of Pressure Kits: 277601-1, 277601-2 and 277601-3

1. Turn off the pump and disconnect the air for safety.
2. Relieve pressure in the system.
3. Disconnect the outlet line from the pump and thread TEE to pump outlet. For 277601-3, install the TEE with a nipple.
4. Thread bung adaptor 277602 or pump tube adaptor 277603 onto the foot of pump.
5. Thread the 90° union swivel into the 3/8" branch of adapter of either 277602 or 277603 with its swivel open toward pump outlet.
6. Thread the reducer bushing (1/2" x 3/8" to the 1/2" TEE branch).
7. Thread the pressure relief valve onto the 3/8" end of the reducer bushing.
8. Thread the coupled hose onto the pressure relief valve with thread sealant.
9. Connect the lower end of coupled hose with the 90° union swivel without using thread sealant. Tighten the swivel nut.

Note: Figure 2 shows kits being installed on PMV pumps.

Installation Procedures of Pressure Kits: 277601-4, 277601-5

1. Turn off pump and disconnect air line for safety. Relieve the pressure in system.
2. Disconnect the fluid inlet line and fluid outlet line at the pump.
3. Thread one TEE to pump outlet and the other to pump inlet.
4. Thread one reducer bushing onto the branch of the TEE at the outlet.
5. Thread the other reducer bushing onto the TEE with planned orientation for nylon tube installation.
6. Thread pressure relief valve onto the reducer at the pump outlet.
7. Thread pipe-to-tube connector onto the branch of TEE. (Avoid connecting the run of TEE if possible).
8. Install nylon tube between these two connectors.
9. Connect inlet line to the inlet TEE, and the outlet line to the outlet TEE.

Americas:
One Lincoln Way
St. Louis, MO 63120-1578
USA
Phone +1.314.679.4200
Fax +1.800.424.5359

Europe /Africa/Middle East
Lincoln GmbH
Heinrich-Hertz-Str. 2-8
69190 Walldorf - Germany
Phone/Fax +49.6227.33-0/-259
www.lincolnindustrial.de

Asia/Pacific:
51 Changi Business Park
Central 2
#09-06 The Signature
Singapore 486066
Phone +65.6588.0188
Fax +65.6588.3438

© Copyright Lincoln Industrial
Corporation 2010
Printed in USA

Web site:
www.lincolnindustrial.com